

RADIO CONTROL MODEL / RC FLUGMODELL

CAC CA-9 WIRRAWAY

BUILDING INSTRUCTIONS / MONTAGEANLEITUNG



SPECIFICATIONS

Model scale: 1/7.5
Wingspan : 1540mm / 60.6 in.
Length : 1120mm / 44.0 in.
Electric power system: 670Kv or equivalent brushless outrunner motor
Glow Engine: 46-70 (7.45cc - 11.5cc)
Radio: Minimum 7 channels radio

Technische Daten

Spannweite: 1540mm
Länge : 1120mm
Elektroantrieb: 670Kv
Verbrennerantrieb: 7.45cc - 11.5cc
Fernsteuerung: 7 Kanäle



WARNING! This radio controlled model is NOT a toy. If modified or flown carelessly it could go out of control and cause serious human injury or property damage. Before flying your airplane, ensure the air field is spacious enough. Always fly it outdoors in safe areas and seek professional advice if you are unexperienced.

ACHTUNG! Dieses ferngesteuerte Modell ist KEIN Spielzeug! Es ist für fortgeschrittene Modellflugpiloten bestimmt, die ausreichende Erfahrung im Umgang mit derartigen Modellen besitzen. Bei unsachgemäßer Verwendung kann hoher Personen- und/oder Sachschaden entstehen. Fragen Sie in einem Modellbauverein in Ihrer Nähe um professionelle Unterstützung, wenn Sie Hilfe im Bau und Betrieb benötigen. Der Zusammenbau dieses Modells ist durch die vielen Abbildungen selbsterklärend und ist für fortgeschrittene, erfahrene Modellbauer bestimmt.

REQUIRED FOR OPERATION (Purchase separately) BENÖTIGTE KOMPONENTEN FÜR DEN ABFLUG (Nicht enthalten)

Gas power



11x6 for .46 - 2 cycle engine
11x7 for .52 - 4 cycle engine

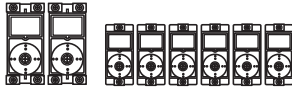

Motor x1. Aileron (mini servo)x2.
Flap (mini servo)x4. Elevator x1. Rudder x1

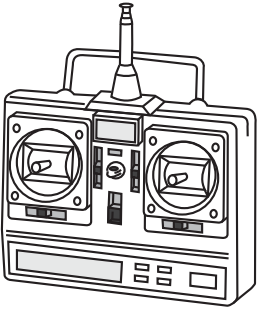

Minimum 7 channels radio
with 8 servos



"Y" extension for flap x4 Extension for aileron

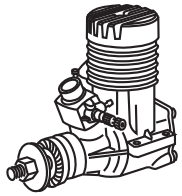

.46~.51 - 2 cycle

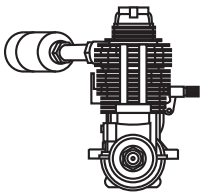

.52~.70 - 4 cycle



Silicone tube

Electric power



13x10 - Electric Motor



670Kv Brushless
out runner Motor

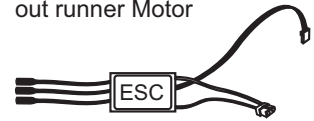

65Amp brushless ESC

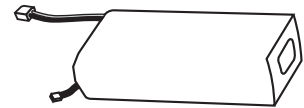

4 cell 14.8v 4500-500Ah
Lipo battery

GLUE (Purchase separately)



Silicon sealer

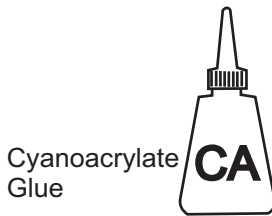

Cyanoacrylate
Glue



Epoxy Glue (5 minute type)
Epoxy Glue (30 minute type)

TOLLS REQUIRED (Purchase separately)

Hobby knife

Phillip screw driver

Hex Wrench

Needle nose Pliers

Scissors

Awl

Sander

Wire Cutters

Masking tape - Straight Edged Ruler - Pen or pencil - Rubbing alcohol - Drill and Assorted Drill Bits

If exposed to direct sunlight and/or heat, wrinkles can appear. Storing the model in a cool place will let the wrinkles disappear. Otherwise, remove wrinkles in covering film with a hair dryer, starting with low temperature. You can fix the corners by using a hot iron.

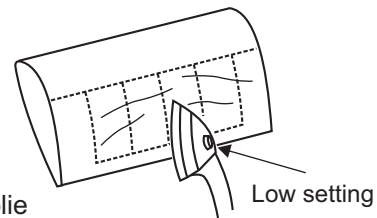

Bei Sonneneinstrahlung und/oder Wärme kann die Folie erschlaffen bzw. Falten entstehen. Verwenden Sie ein Warmluftgebläse (Haartrockner) um evtl. Falten aus der Folie zu bekommen. Die Kanten können Sie mit einem Bügeleisen behandeln. Nicht zuviel Hitze anwenden!

Symbols used throughout this instruction manual, comprise:

Drill holes using the stated size of drill (in this case 1.5 mm Ø)

Take particular care here

Hatched-in areas: remove covering film carefully

Check during assembly that these parts move freely, without binding

Use epoxy glue

Apply cyano glue

Assemble left and right sides the same way.

Not included. These parts must be purchased separately

Löcher bohren mit dem angegebenen Bohrer (hier 1,5 mm)

Hier besonders aufpassen

Schraffierte Stellen, Bespannfolie vorsichtig entfernen

Während des Zusammenbaus immer prüfen, ob sich die Teile auch reibungslos bewegen lassen

Epoxy-Klebstoff verwenden

Sekundenkleber auftragen

Linke und rechte Seite wird gleichermaßen zusammgebaut

Nicht enthalten. Teile müssen separat gekauft werden.

SAFETY NOTES BEFORE ASSEMBLING

This model is highly pre-fabricated and can be built in a very short time. However, the work which you have to carry out is important and must be done carefully.

The model will only be strong and fly well if you complete your tasks competently - so please work slowly, accurately and check every joints, maybe apply more glue to be safe.

Read through the manual before you begin, so you will have an overall idea of what to do.

CONTENTS OF KIT

- A. Fuselage
- B. Right wing half with aileron and flap
- C. Left wing half with aileron and flap
- D. Center wing with flap
- E. Vertical stabilizer with rudder
- F. Horizontal stabilizer with elevator

- 1. Pushrods
- 2. Main landing gear
- 3. Tail landing gear
- 4. Engine mount set
- 5. Wheels
- 6. Fuel tank and hardware
- 7. Control horn
- 8. Wing joiner
- 9. Hardware bag
- 10. Building instruction

Note: The aileron control surfaces have already been pre-hinged and pre-glued at the factory. However, it is recommended that you check integrity of each of these control surface. To do so, grasp the respective item, in this case the wing halves, and apply medium pressure, trying to separate the aileron from the wing.

! The painted and plastic parts used in this kit are fuel roof. However, they are nottolerant of many harsh chemicals including the following: paint thinner, CA glue accelerator, CA glue debonder and acetone. Do not let these chemicals come in contact with the colors on the covering and the plastic parts.

CONVERSION TABLE

1.0mm = 3/64"	3.0mm = 1/8"	10mm = 13/32"	25mm = 1"
1.5mm = 1/16"	4.0mm = 5/32"	12mm = 15/32"	30mm = 1-3/16"
2.0mm = 5/64"	5.0mm = 13/64"	15mm = 19/32"	45mm = 1-51/64"
2.5mm = 3/32"	6.0mm = 15/64"	20mm = 51/64"	

HISTORY:

The CAC Wirraway is a multi-role trainer and military aircraft produced in Australia by the Commonwealth Aircraft Corporation (CAC) from 1939 to 1946. It was an Australian development of the North American NA-16 trainer. The Wirraway is considered the cornerstone of Australian aircraft manufacturing.

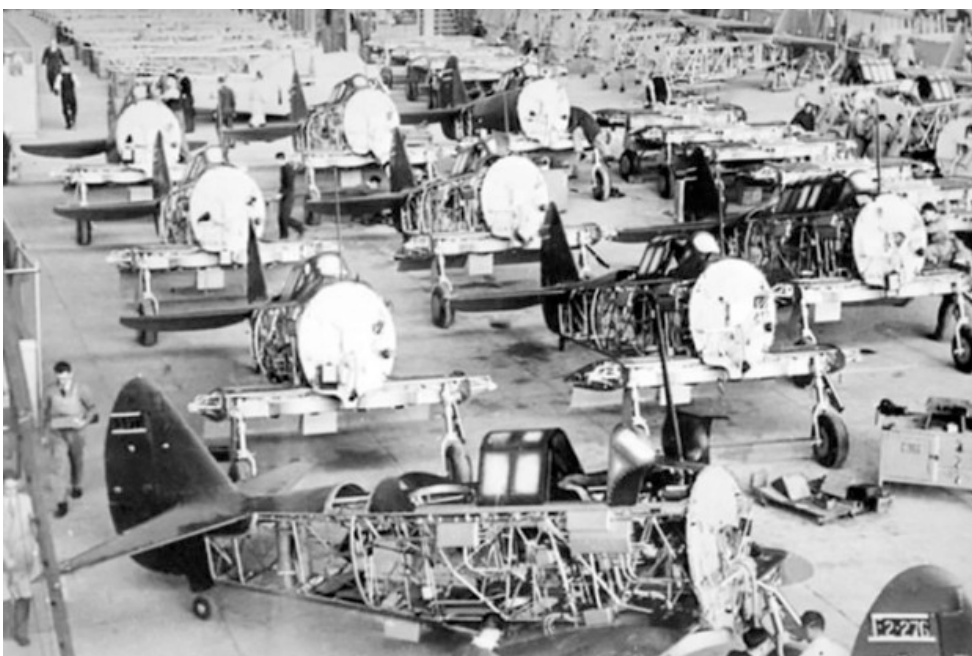

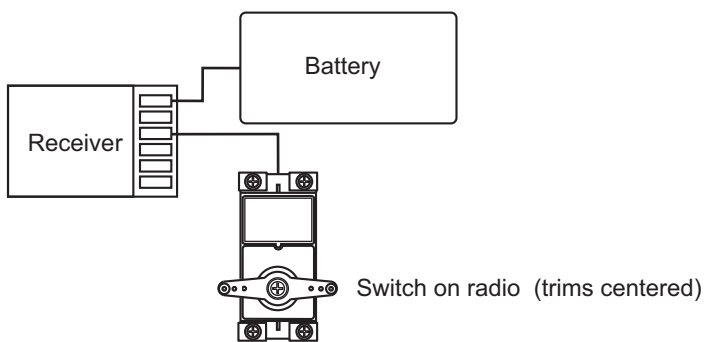
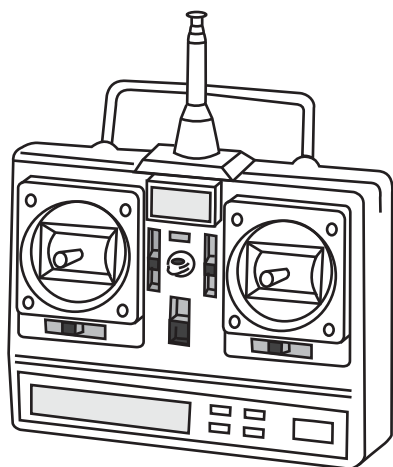

Le palonnier du servo doit être perpendiculaire au servo, comme indiqué sur le schéma ci-dessous

The servo horn should be perpendicular to the servo as shown on the drawing below.

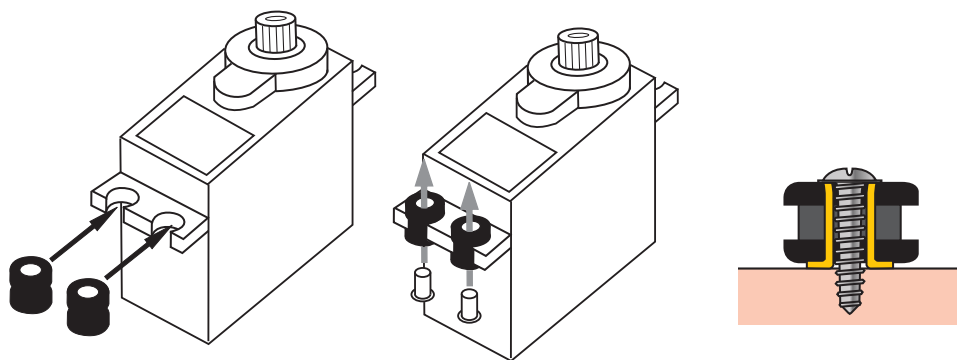
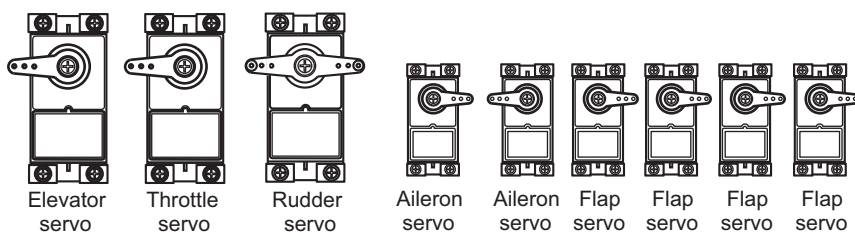
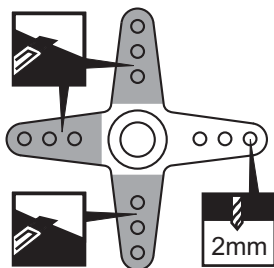

Monter les silent blocs et les oeuillets sur le servo comme montré sur la photo et le schéma.

Assemble grommets and eyelets to the servo as shown on photo and drawing.

2mm hole connector.
4

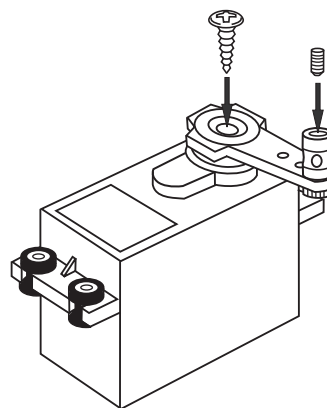
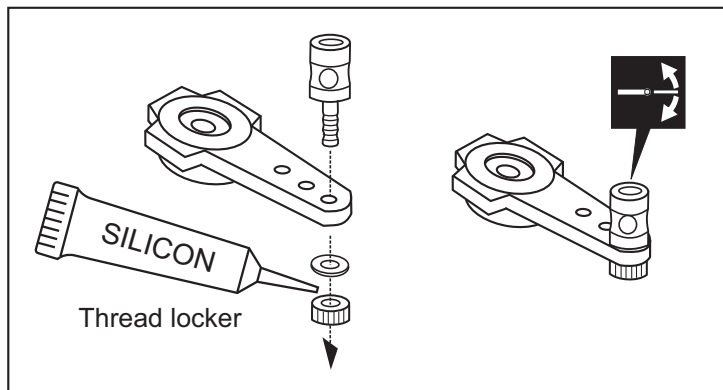

Wirraway 1- Wing: Fixed gear assembly

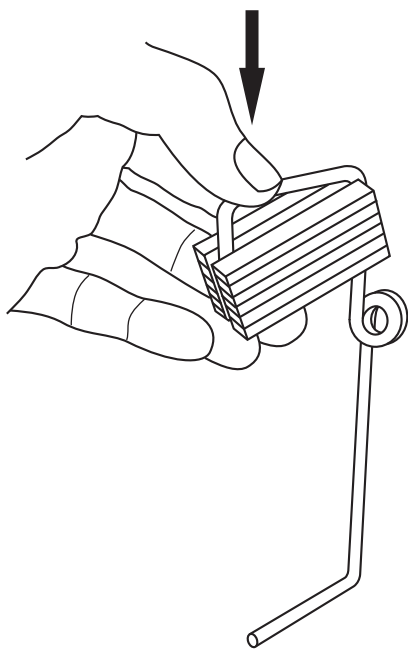

1A

Slide the landing gear onto the plywood gear mount and push the landing gear as shown.

TOP VIEW

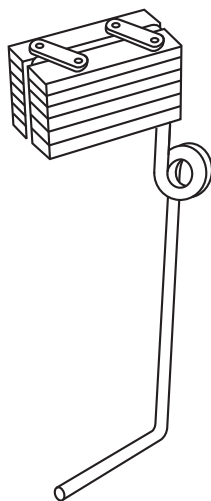

1B

Using the nylon gear strap as a template, mark the plywood gear mount where the four holes to be drill.

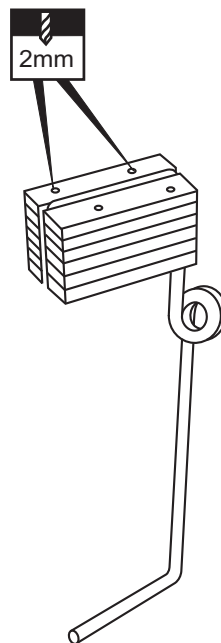

1C

Remove the nylon gear strap and drill a 2mm hole at each of the four marks marked.

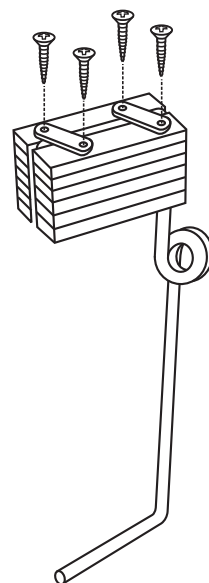

1D

Reposition the nylon gear strap and secure them in place using four 3x20mm screws.

BOTTOM VIEW

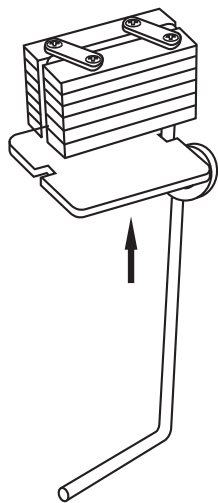

1E

Attach the ply gear mount plate to the plywood gear mount

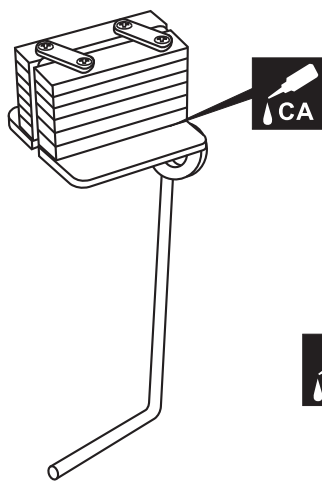

1F

Secure the ply gear mount plate in place using CA glue.

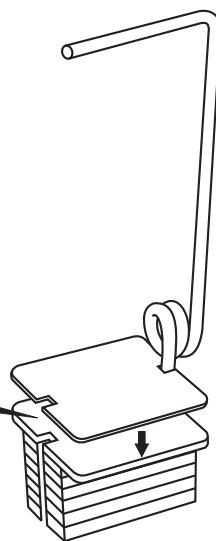

1G

Attach the square plastic onto the ply gear mount, secure it in place using CA glue.

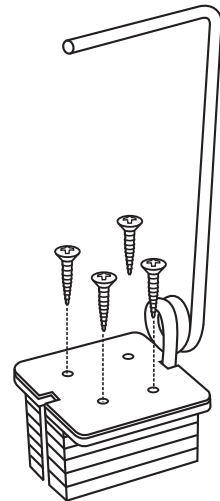

1H

Drill a 2mm holes through the square plastic and ply gear mount plate. Secure the ply gear mount using four 3x20mm screws.

3x20mm screw
16



Plywood Gear mount
 x 2



Square plastic
 x2



Ply gear mount
 plate x 2

Nylon gear strap
4

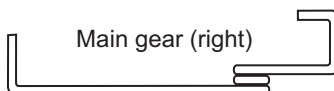

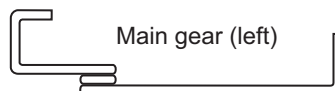

Main gear (right)

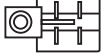

Main gear (left)

Wirraway 3- Wing: Wheels

- 2
- 4mm collar 2
- Plastic strap 2

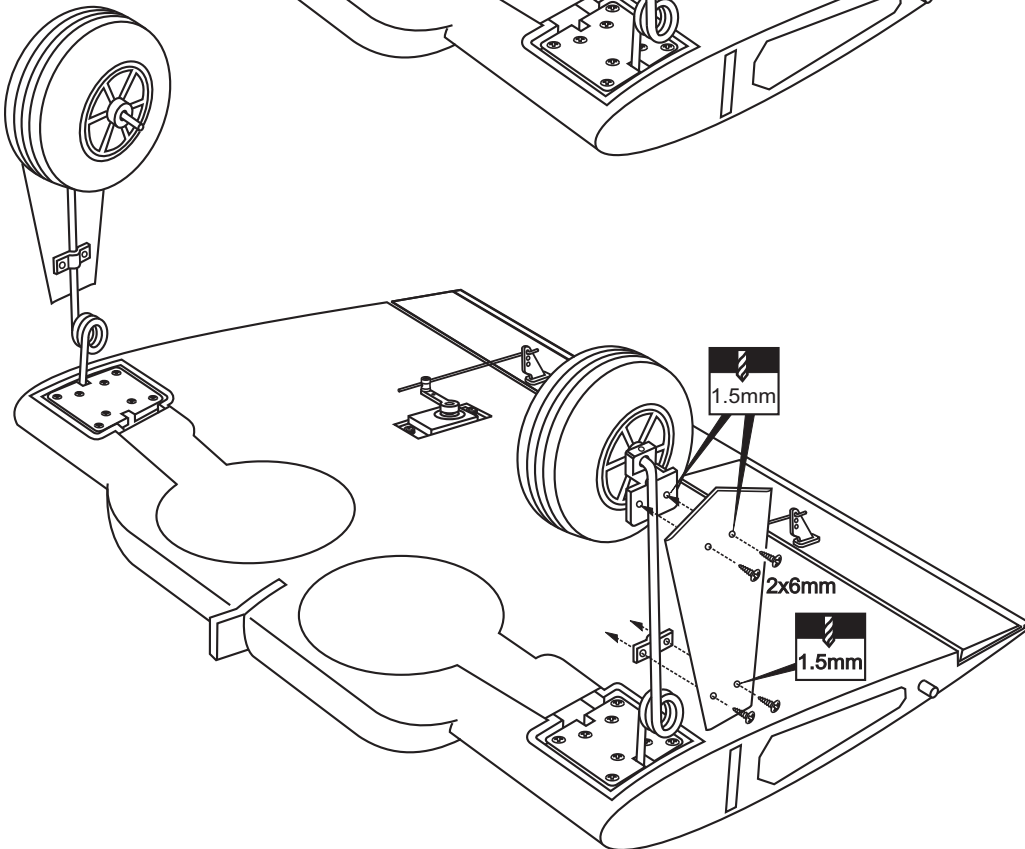
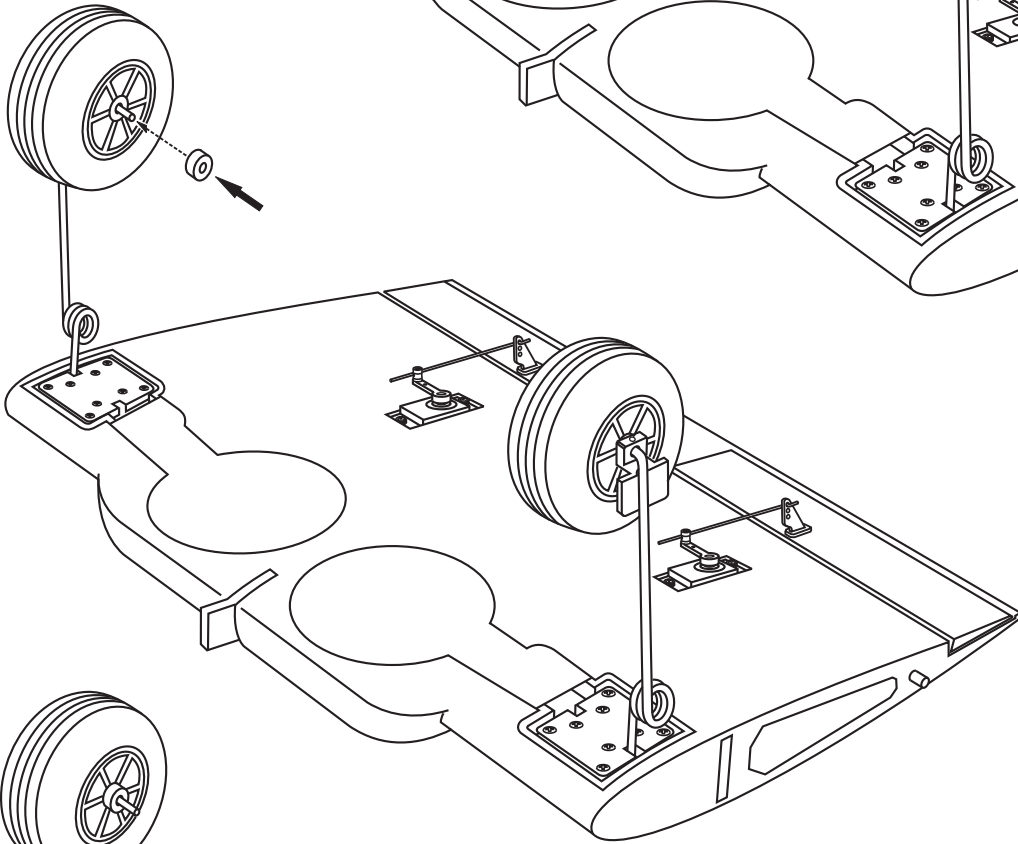
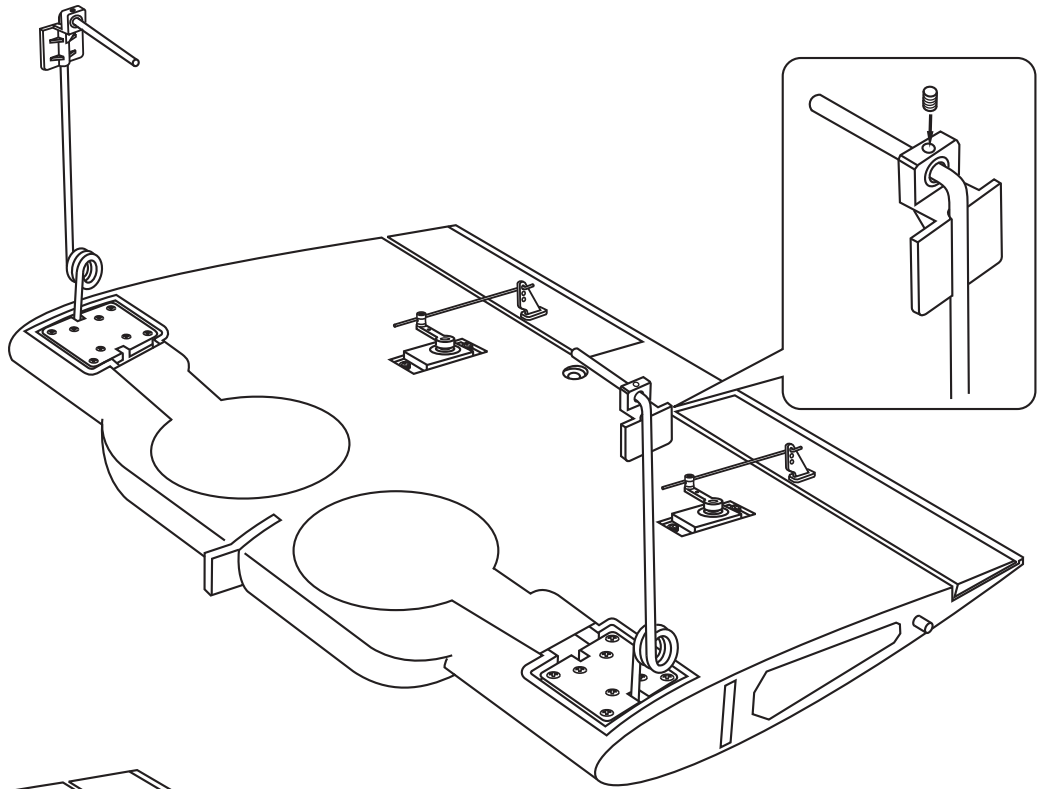

Wirraway 4- Wing: Retract

X Retracts must be purchase separately
VQ-ARE01

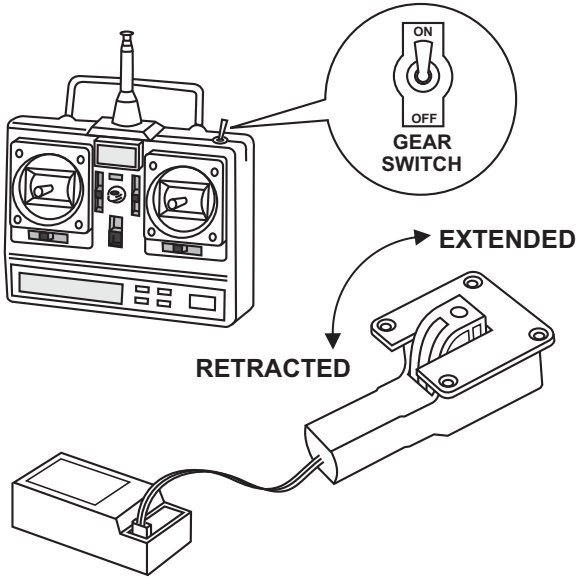

Extend retract with your transmitter and receiver or with servo driver.

1

Power supply: 4.8 to 6.0Volts
GP or EP Aircraft 40-60 class

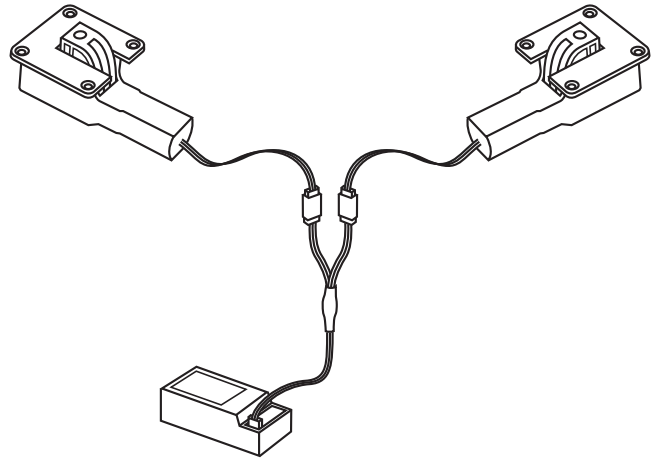
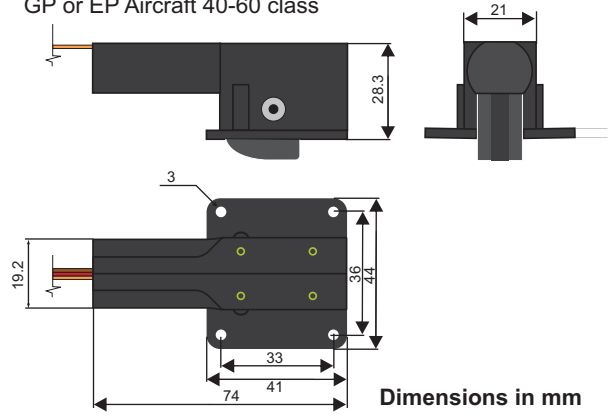

Radio connection

- 1-Plug the connector from each of the retract unit into the 2 in 1 wire harness (not supplied).
- 2-Plug the single lead from the wire harness into the gear channel of your receiver. An auxiliary channel can be used if the gear channel is occupied.

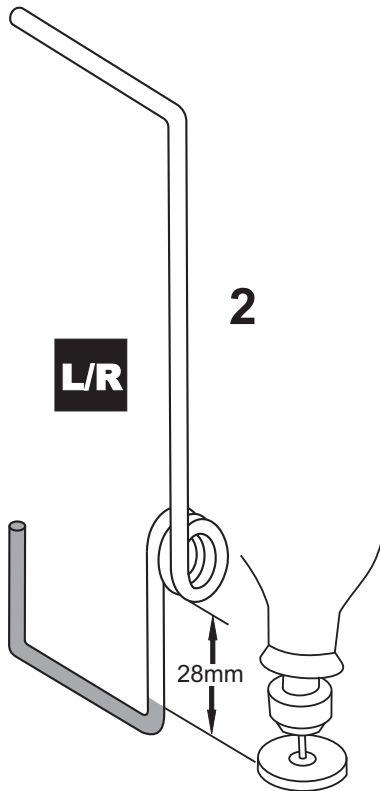

2

L/R

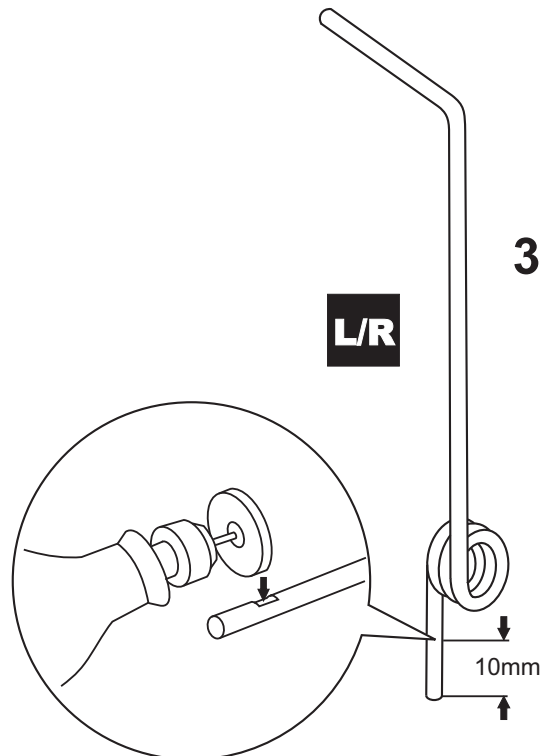

3

L/R

Make a key area with a file on main landing gear.

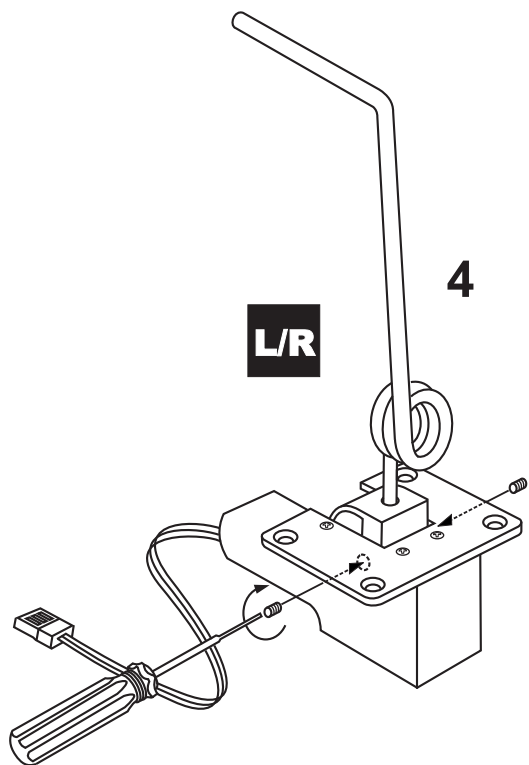

Fix the main landing gear in the retract with hexagon socket screws.

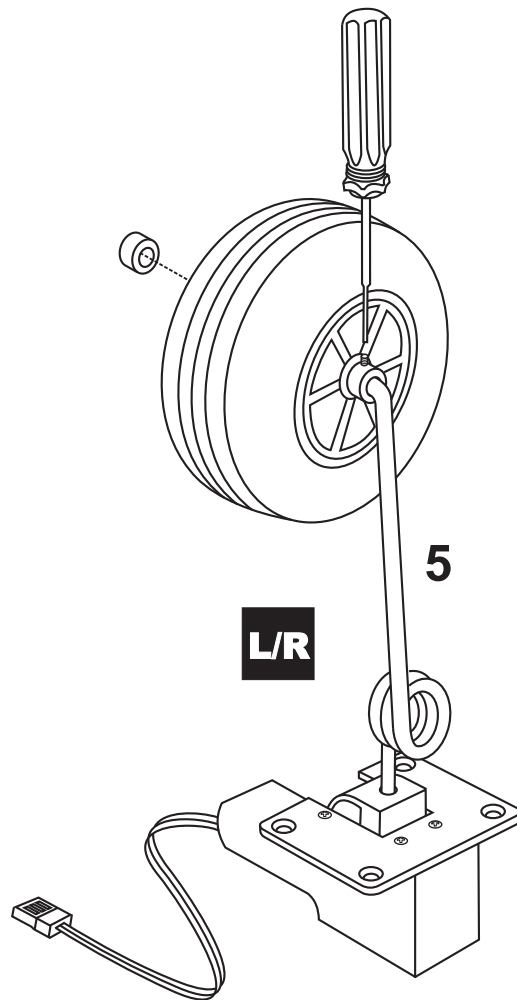

Operation

Before operating the retracts in the model for the first time, check that there are no obstructions in the wheel that could impede operation of the gear.

Turn on transmitters and then receiver. Use the gear of other assigned switch to activate that landing gear and check that it operates correctly.

If the switch direction is opposite of that desired, use the reversing function in the transmitter to change the retraction direction.

If using a 2.4GHz radio, once you have set the correct servo direction, be sure to rebind the system before flight.

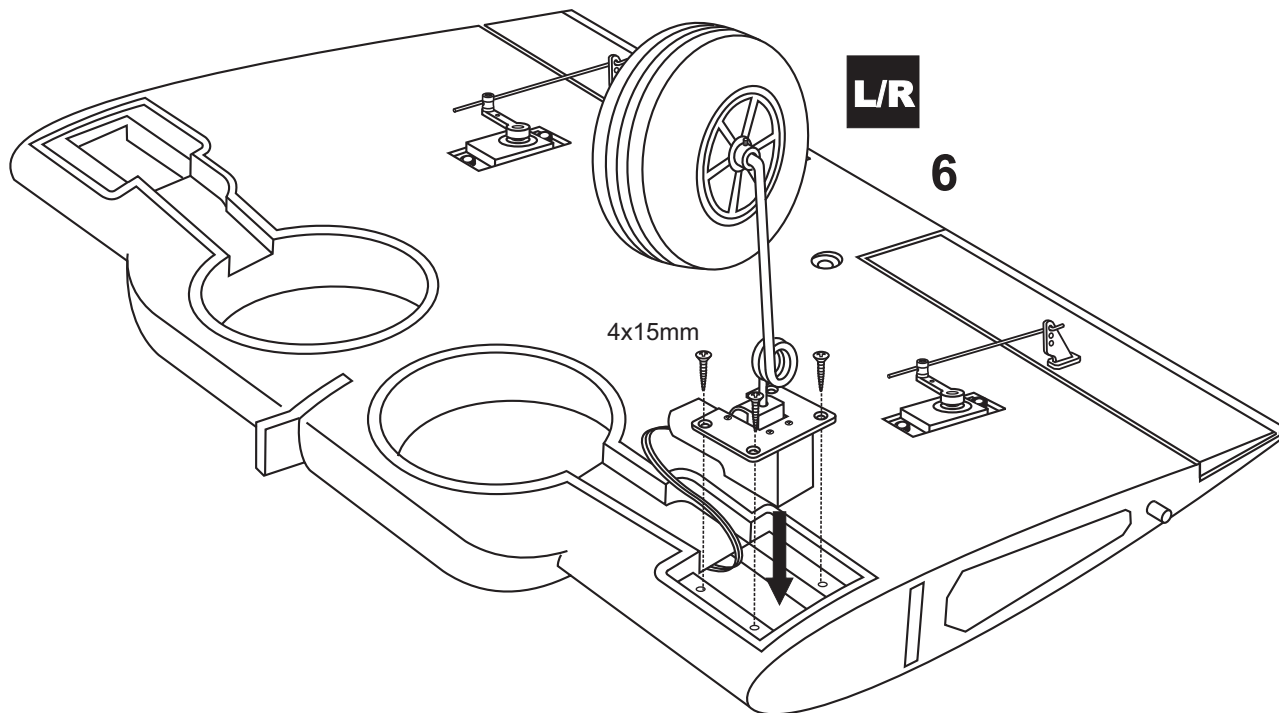

Wirraway 6- Joining the wings

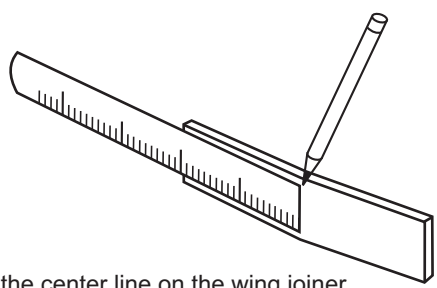

Draw the center line on the wing joiner

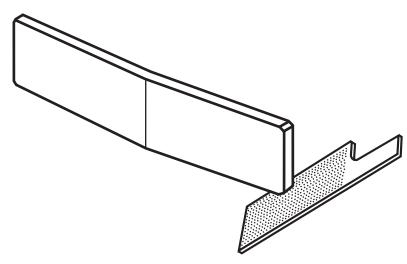

Use a sander to bevel the corner of the wing brace.

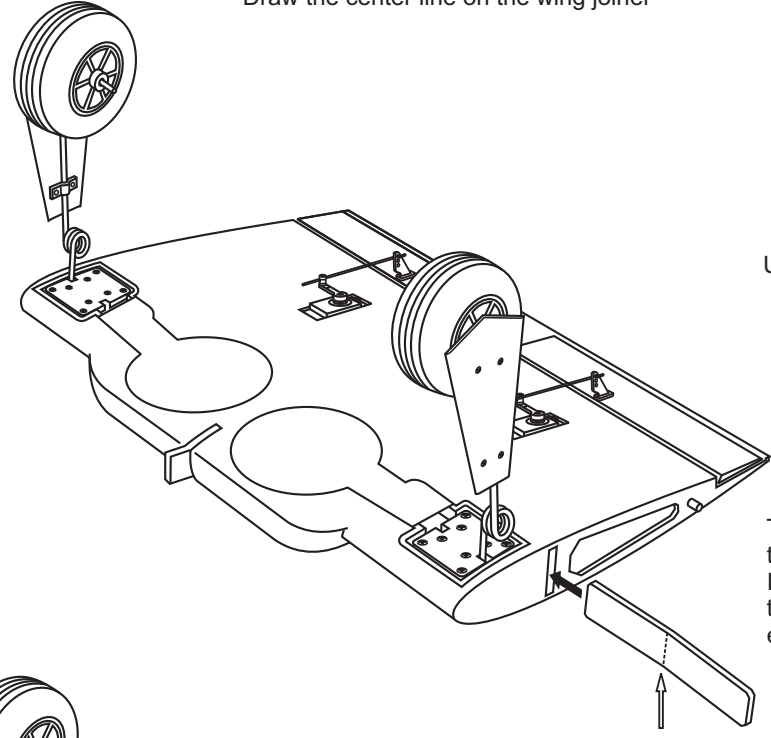

Trial fit each part before gluing . Be certain that there are no gaps.
If the parts will join, but with a gaps, sand or trim the parts a little at a time until the parts meet exactly with no gaps.

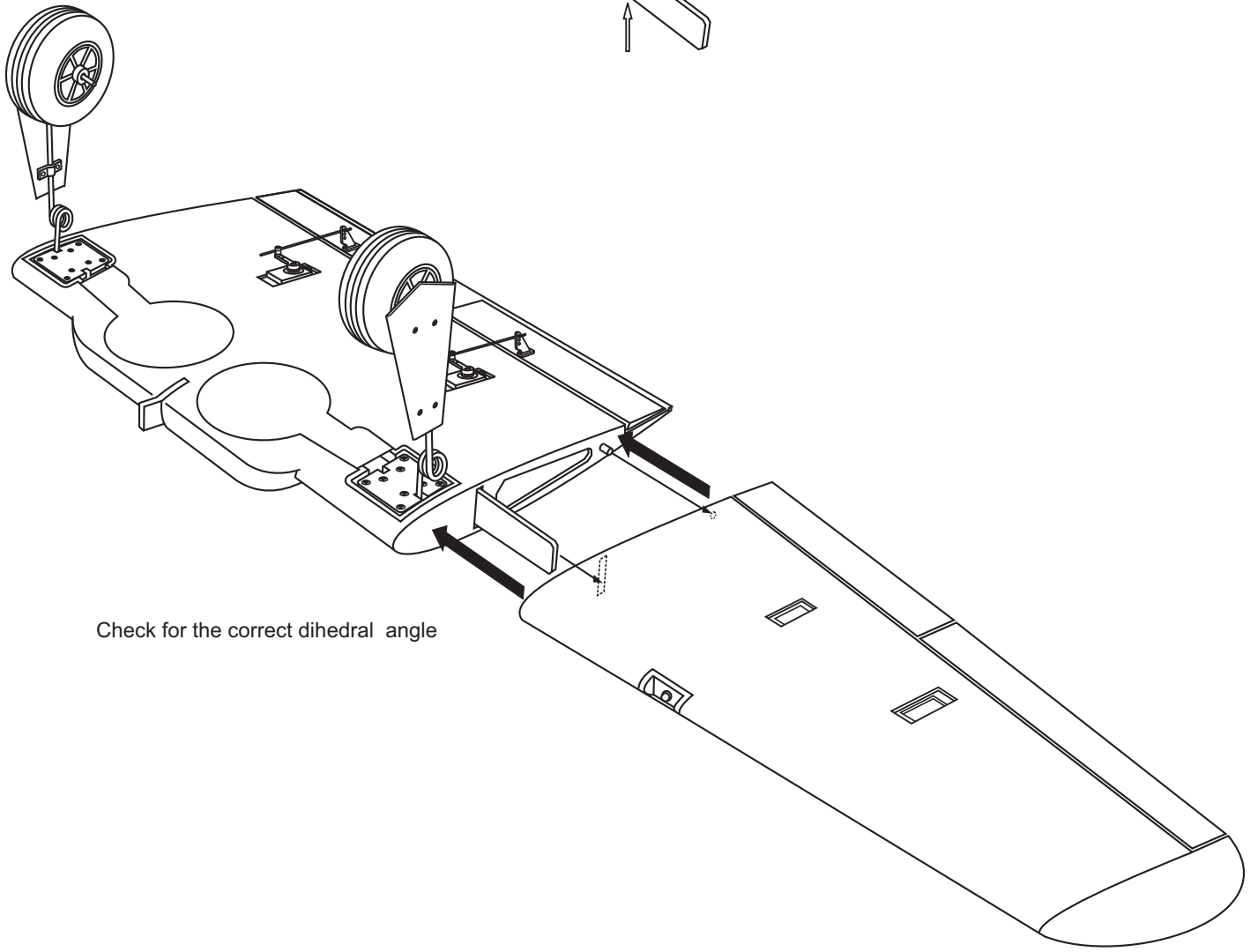

Check for the correct dihedral angle

Wirraway 7- Lights

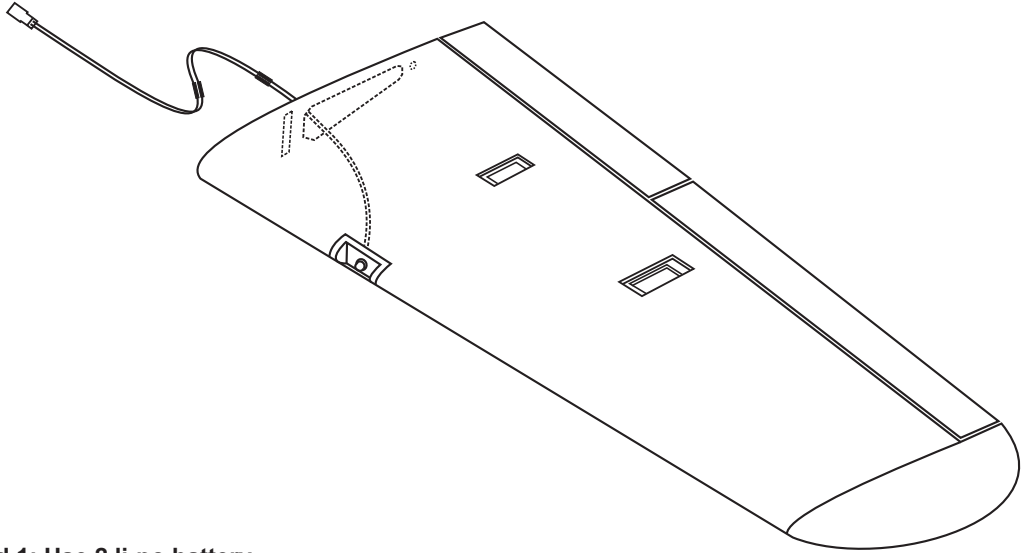
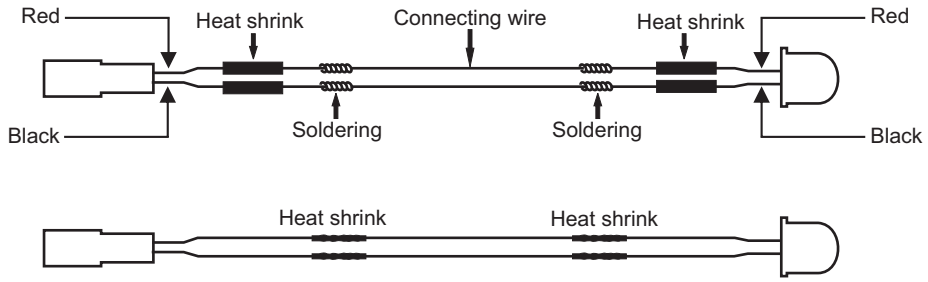

Method 1: Use 2 li-po battery

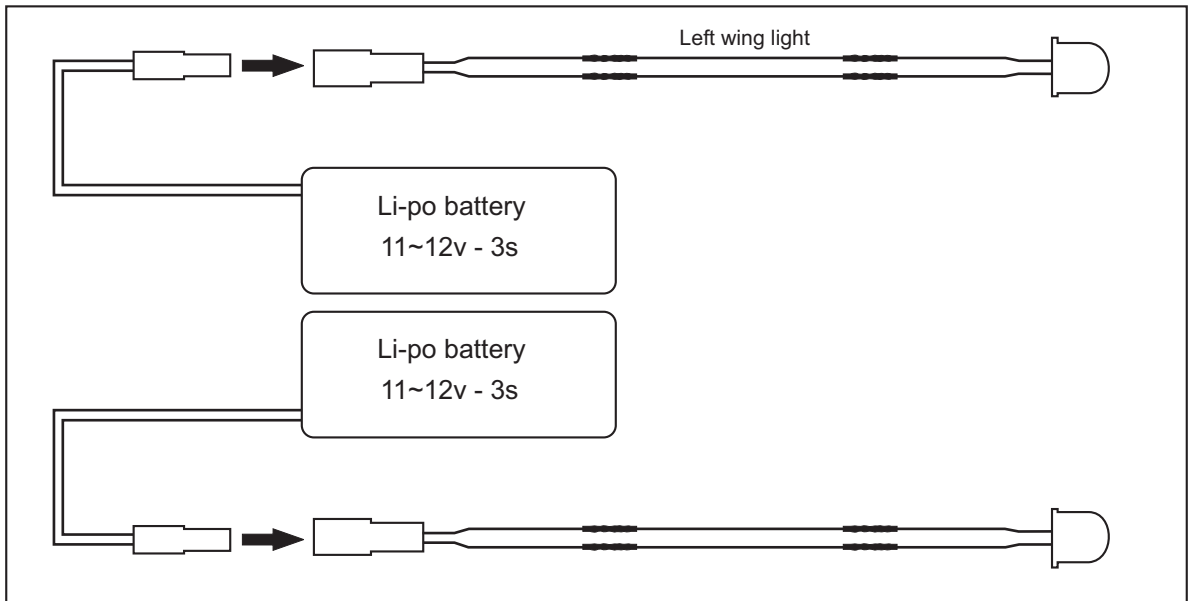

Method 2: Use 1 li-po battery with "T" connector

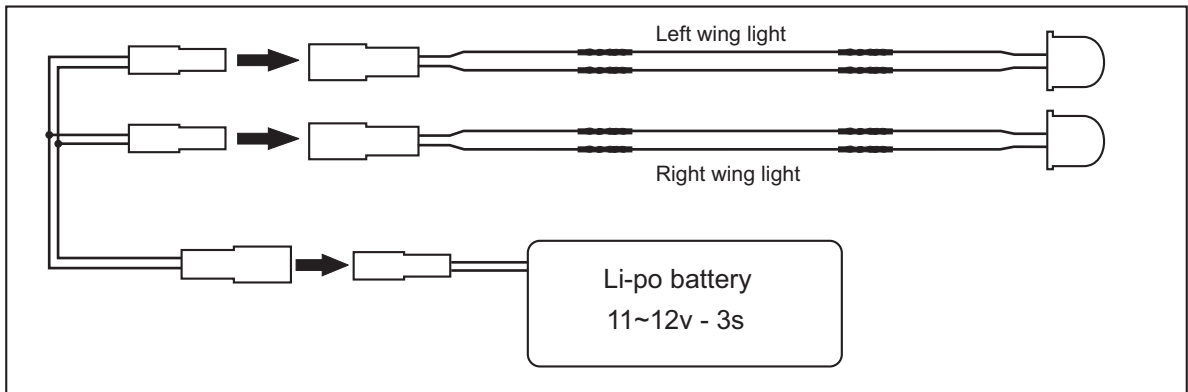

Wirraway 8- Joining the wings

Apply the generous amount of epoxy into the wing cavity of the center wing.

Coat one half of the dihedral brace with epoxy up to the center line. Install the epoxy-coated side of the dihedral brace into the wing joiner cavity up to the center line, making sure that the "V" of the dihedral brace is positioned correctly.

L/R Assemble left and right wings the same way.

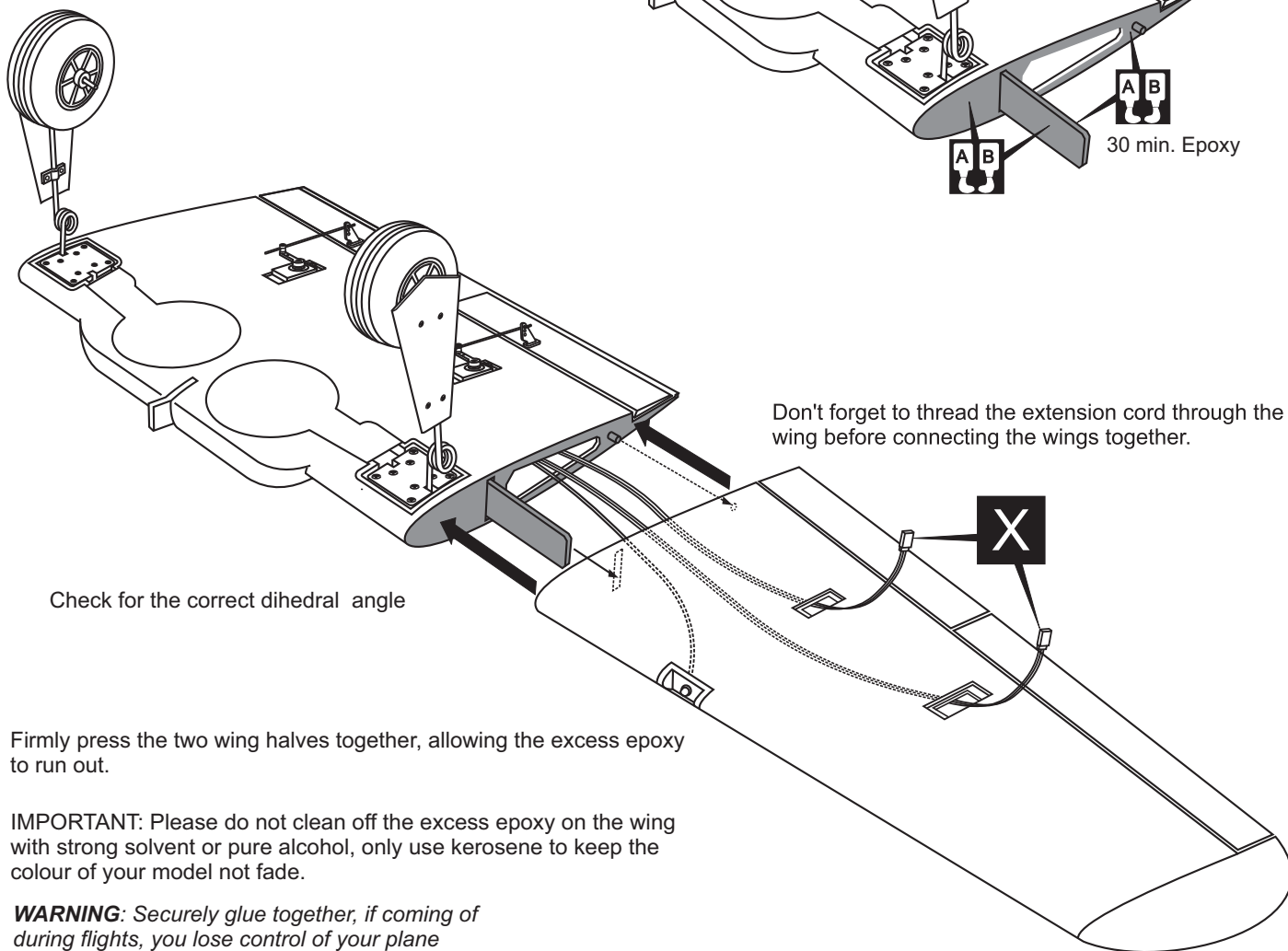
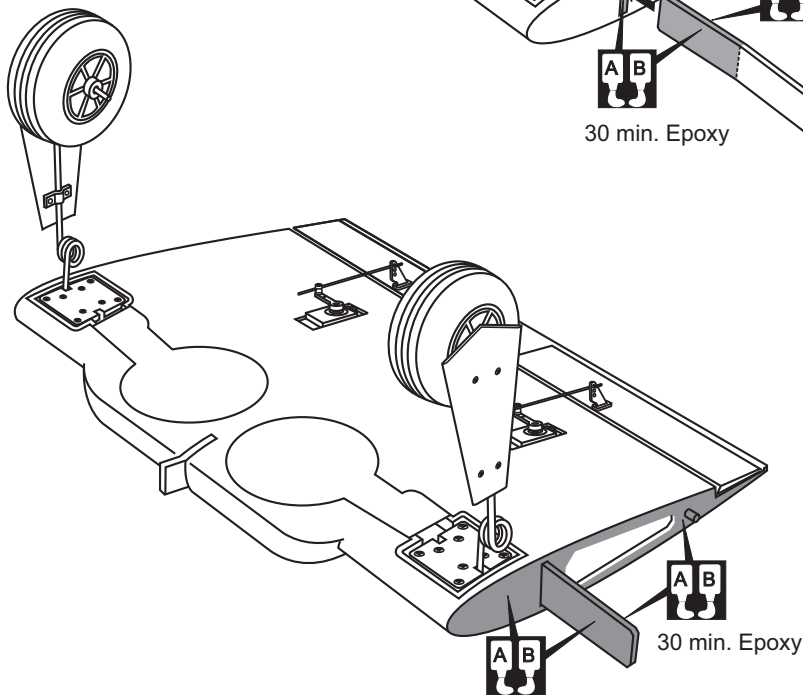
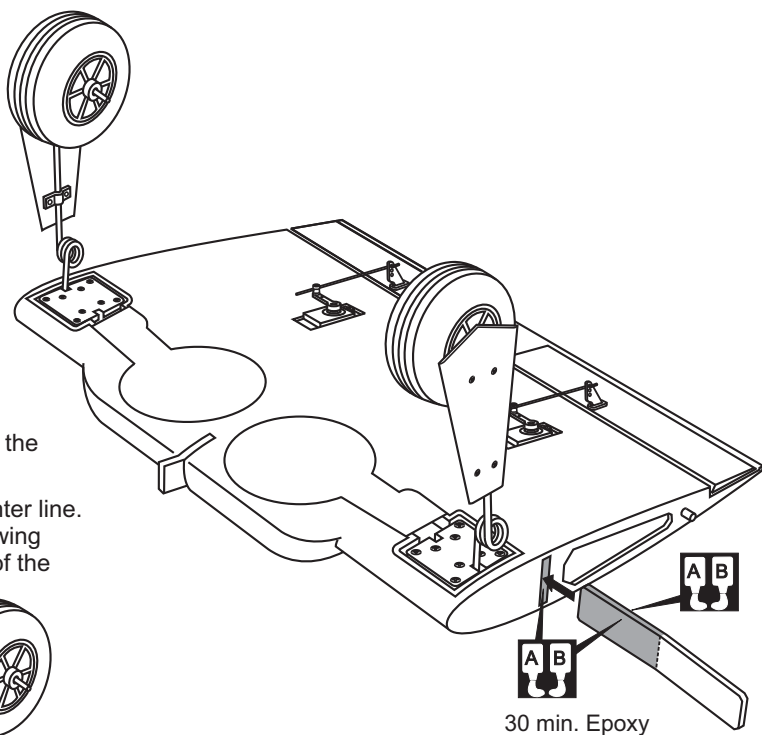

Check for the correct dihedral angle

Don't forget to thread the extension cord through the wing before connecting the wings together.

Firmly press the two wing halves together, allowing the excess epoxy to run out.

IMPORTANT: Please do not clean off the excess epoxy on the wing with strong solvent or pure alcohol, only use kerosene to keep the colour of your model not fade.

WARNING: Securely glue together, if coming off during flights, you lose control of your plane which lead to accidents.

Wirraway 9- Aileron & Flap linkages

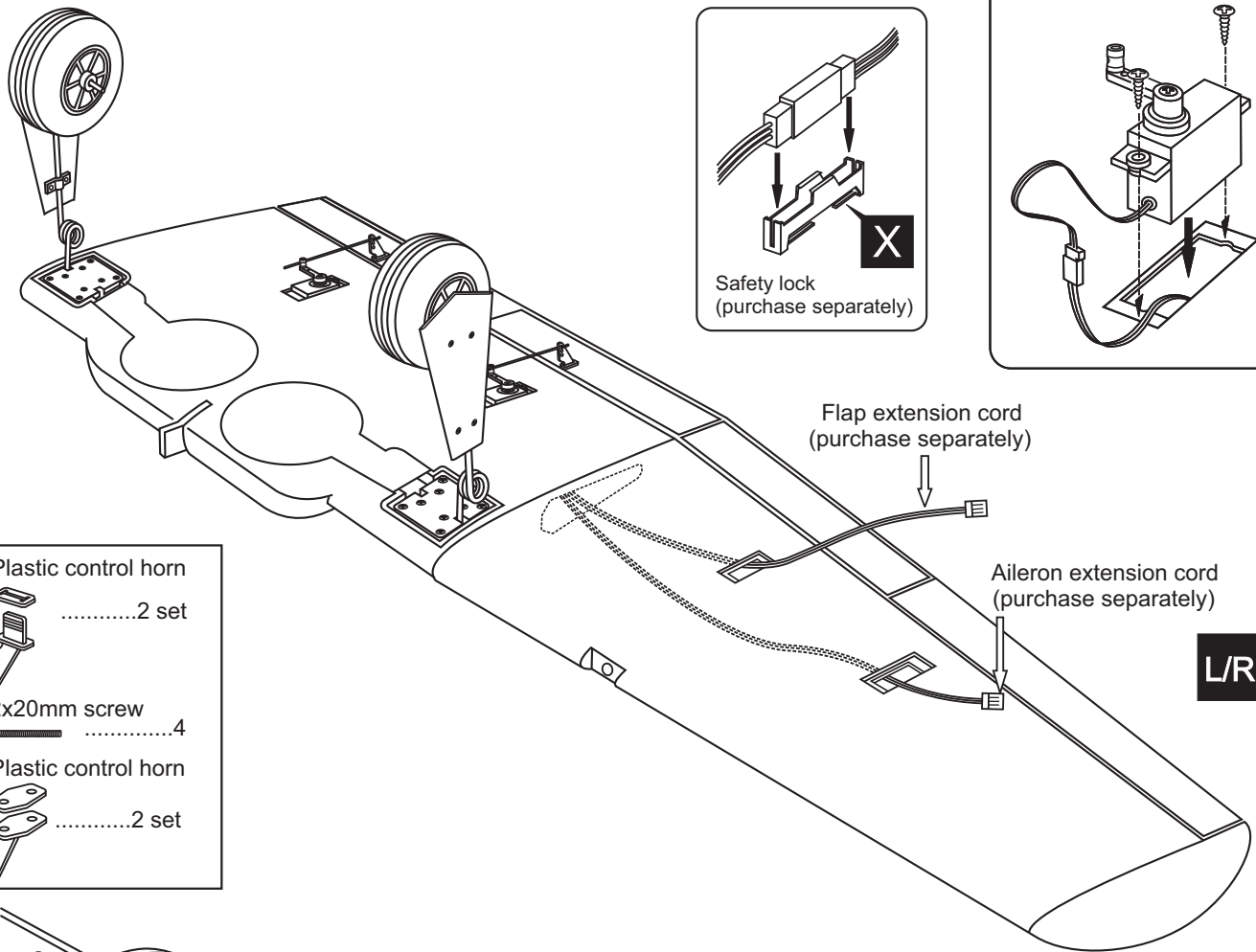

- Plastic control horn2 set
- 2x20mm screw4
- Plastic control horn2 set

L/R

Note: The rectangular hole on the bottom of the flap is pre-cut at factory.

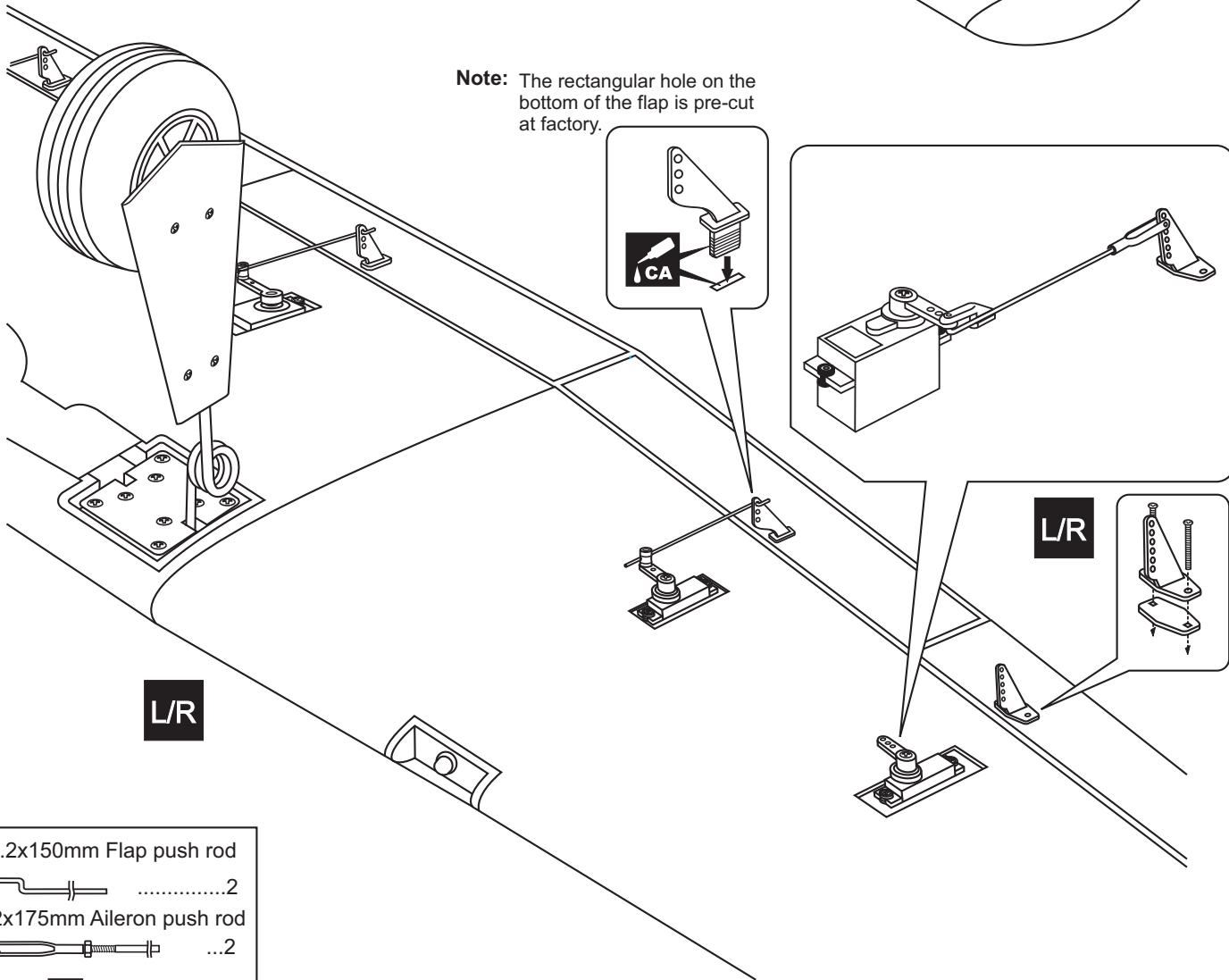

L/R

L/R

- 1.2x150mm Flap push rod2
- 2x175mm Aileron push rod2
- EZ link2

Wirraway 10- Sample connection

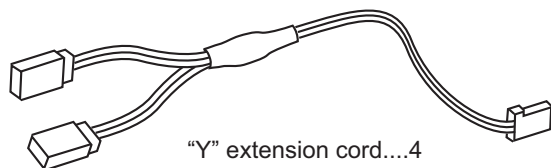
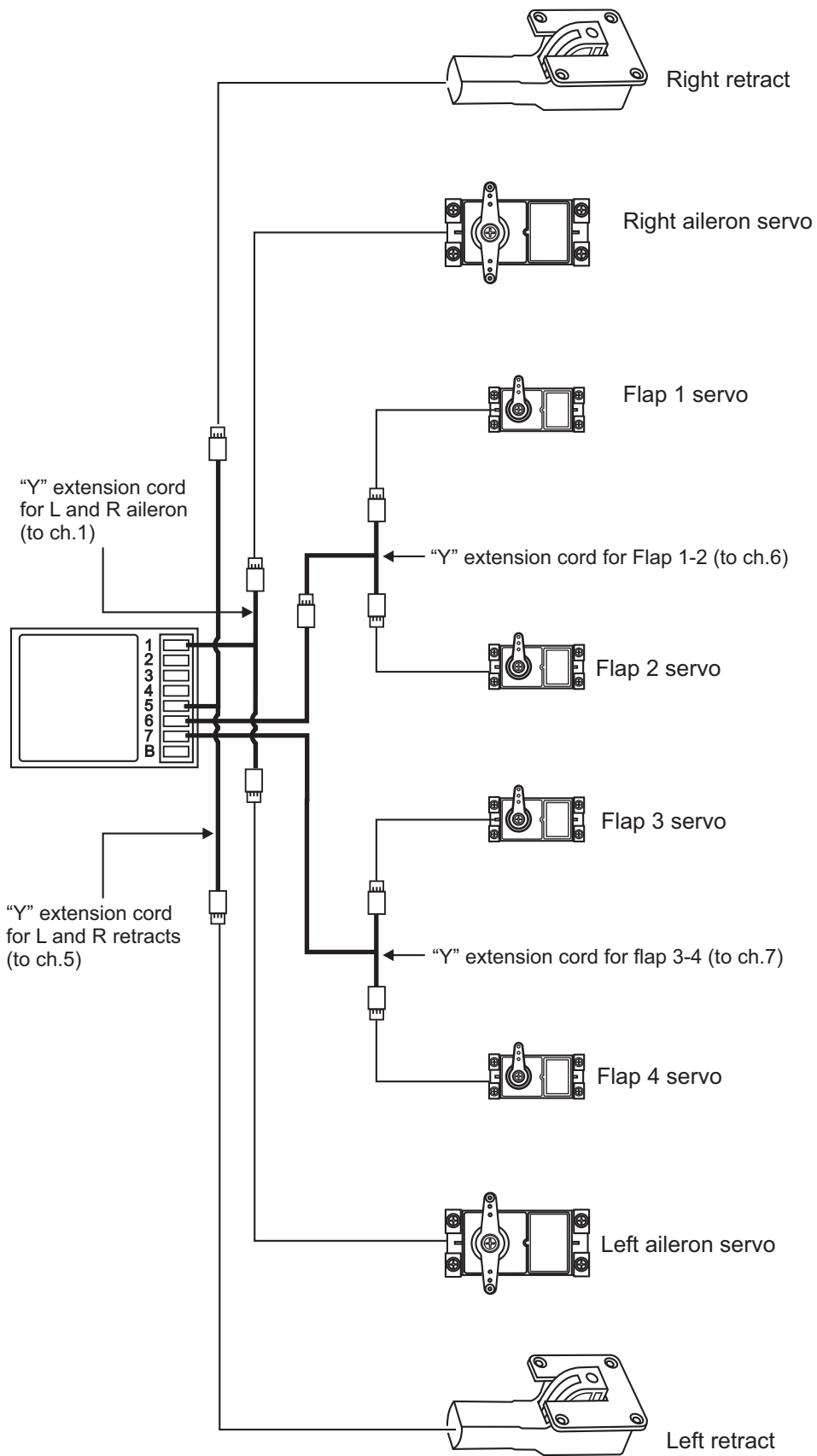

Wirraway 11- Wing installation

6x50mm nylon bolt



....2

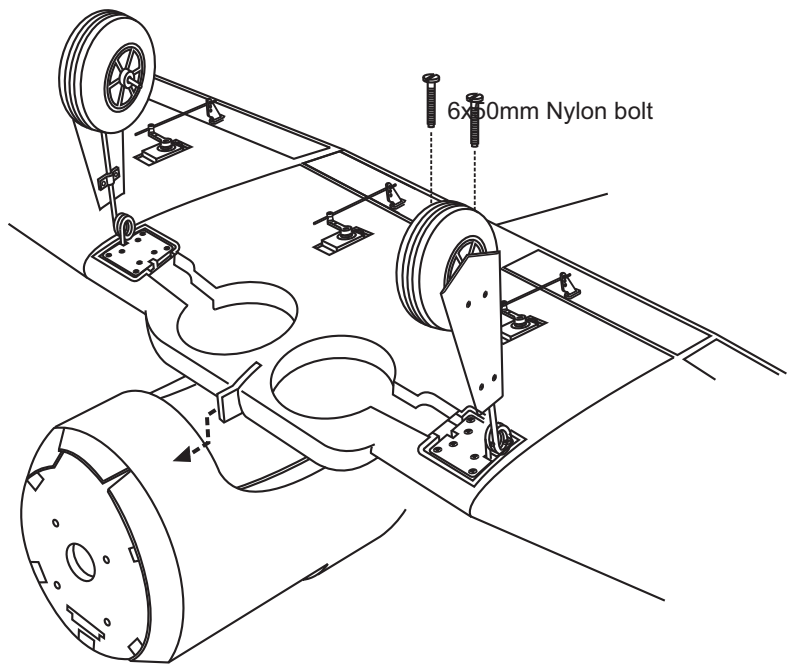

Wirraway 12- Horizontal stabilizer

Cut away only the covering

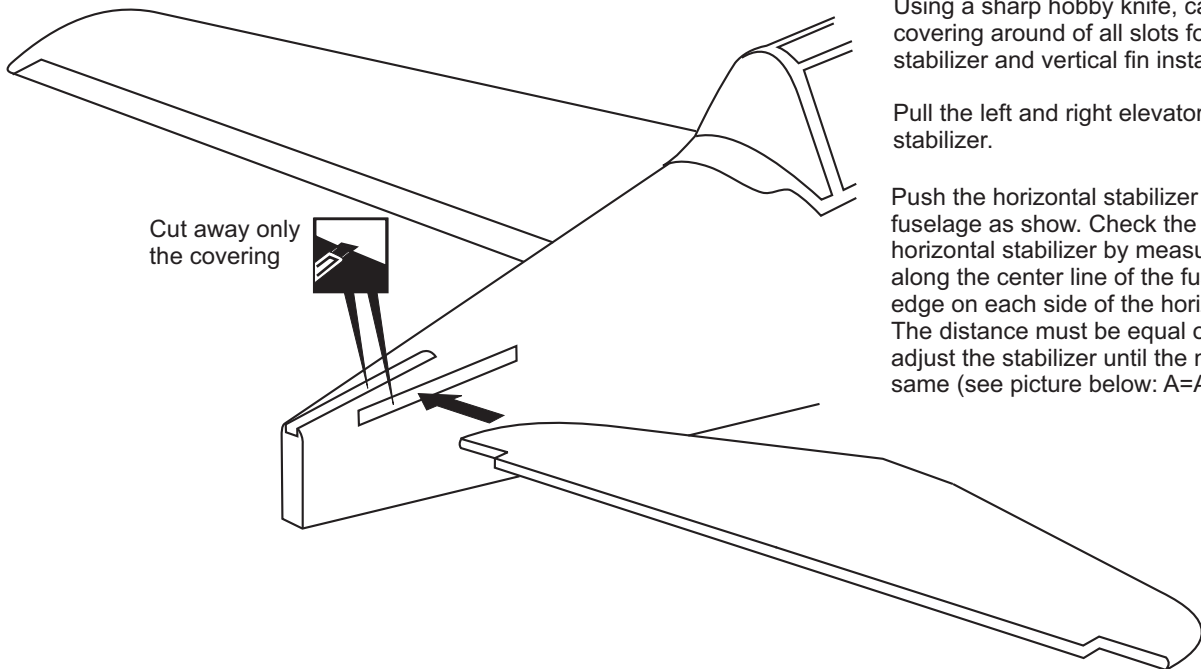

Using a sharp hobby knife, carefully cut away the covering around of all slots for the horizontal stabilizer and vertical fin installation.

Pull the left and right elevator out of the horizontal stabilizer.

Push the horizontal stabilizer into the slot on the fuselage as show. Check the alignment of the horizontal stabilizer by measuring from a fixed point along the center line of the fuselage to the leading edge on each side of the horizontal stabilizer. The distance must be equal on both sides . If not, adjust the stabilizer until the measurements are the same (see picture below: $A=A'$).

When you are satisfied with the alignment, use a pencil to trace around the top and bottom of the stabilizer where it meets the fuselage.

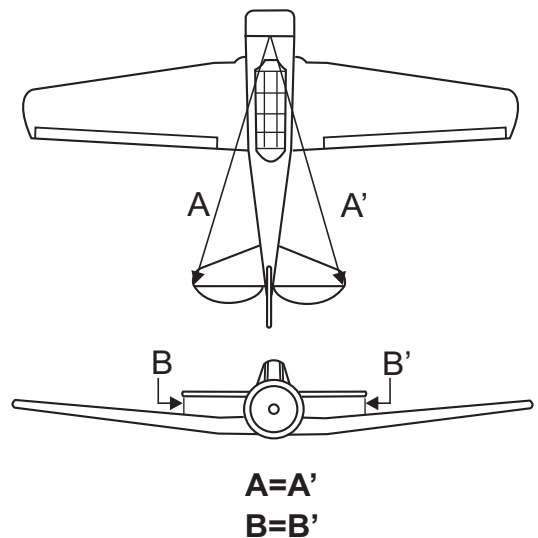
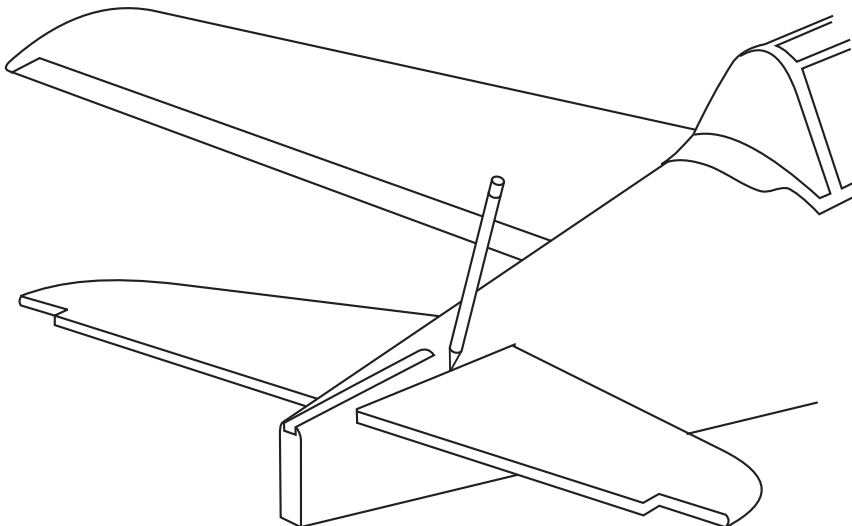

Wirraway 13- Horizontal stabilizer

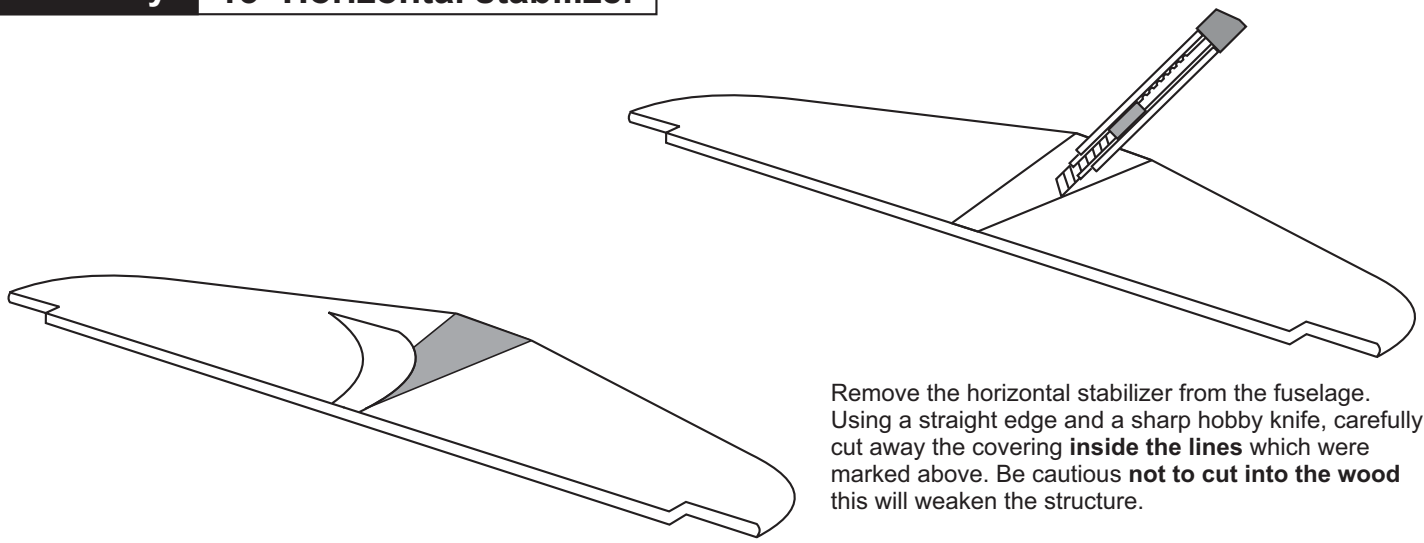

Apply thin CA glue into the slot where the fuselage meet the horizontal stabilizer,



Apply thin CA glue both side

Install the horizontal stabilizer onto the fuselage and adjust the alignment as described in previous step. Note: it is important to ensure that the horizontal stabilizer is also level in regards to the fuselage. Apply the thin CA along the area where the covering was removed in the previous step and to the fuselage where the horizontal stabilizer mounts.

! Securely glue together. If coming off during fly, you lose control of your air plane.

Wirraway 14- Vertical stabilizer

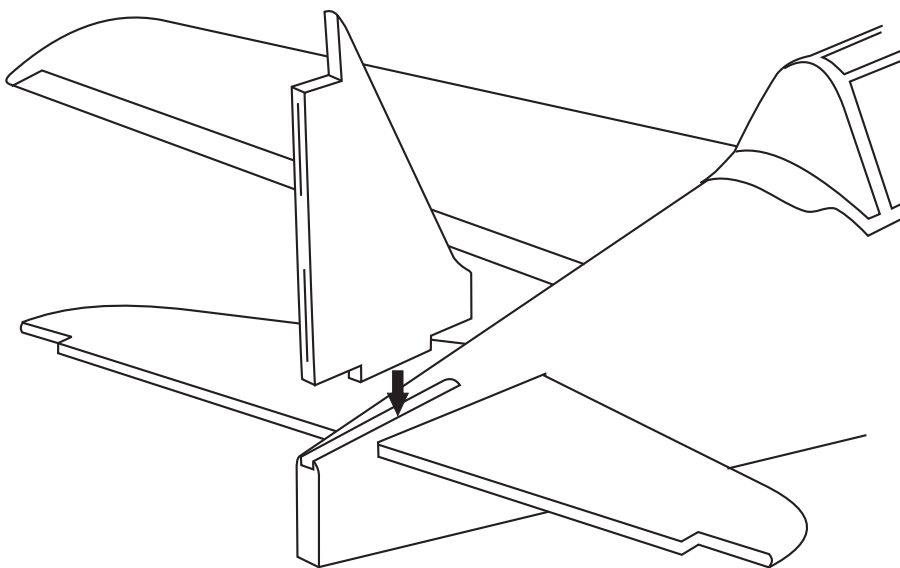

Pull the rudder out of the vertical fin. Carefully, push the vertical fin into the slot on the fuselage as shown.

Wirraway 15- Vertical stabilizer

Using a pencil, trace around the vertical stabilizer where it meets the fuselage. Remove the vertical stabilizer from the fuselage. Using a sharp hobby knife, carefully cut away the covering **below the lines** which were drawn in the previous step. **Do not cut into the woods** as this will affect the structural integrity of the stabilizer.

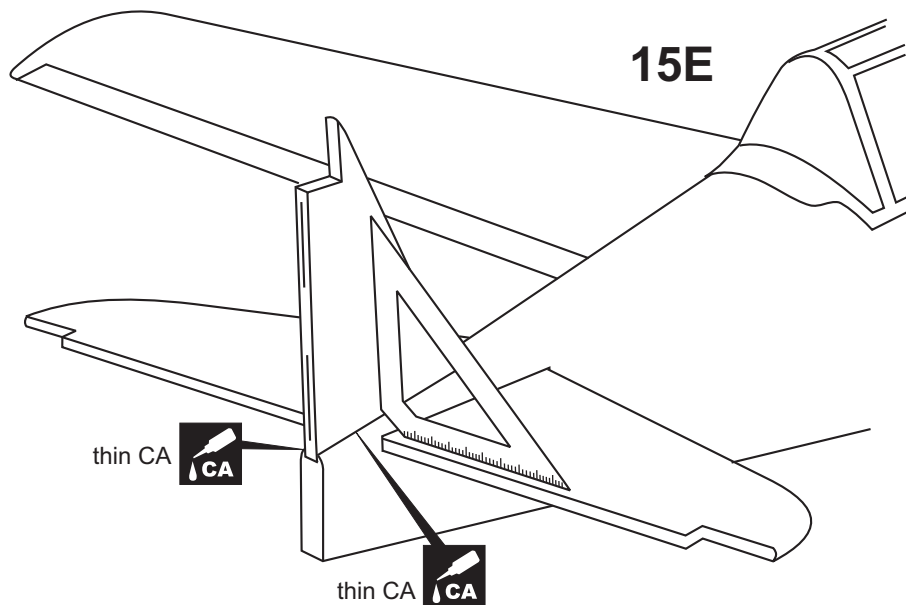
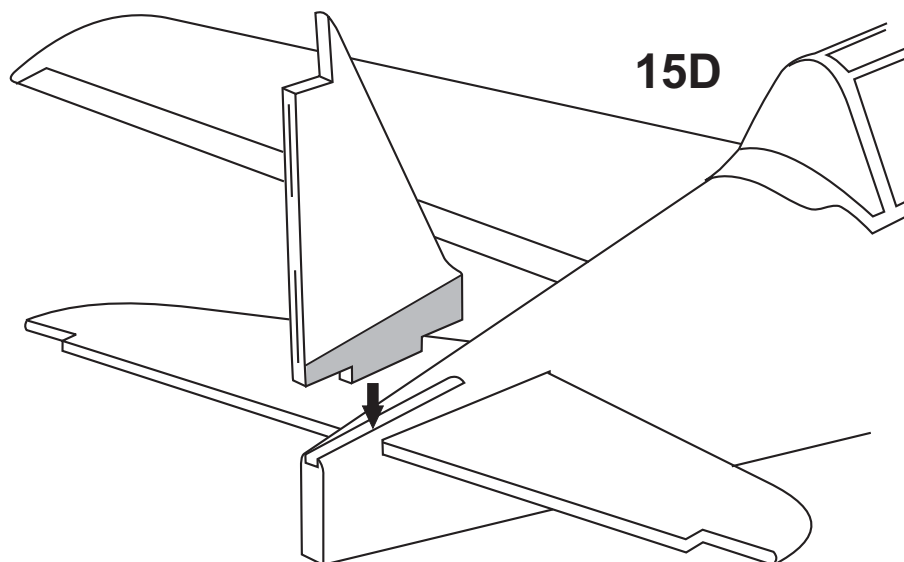
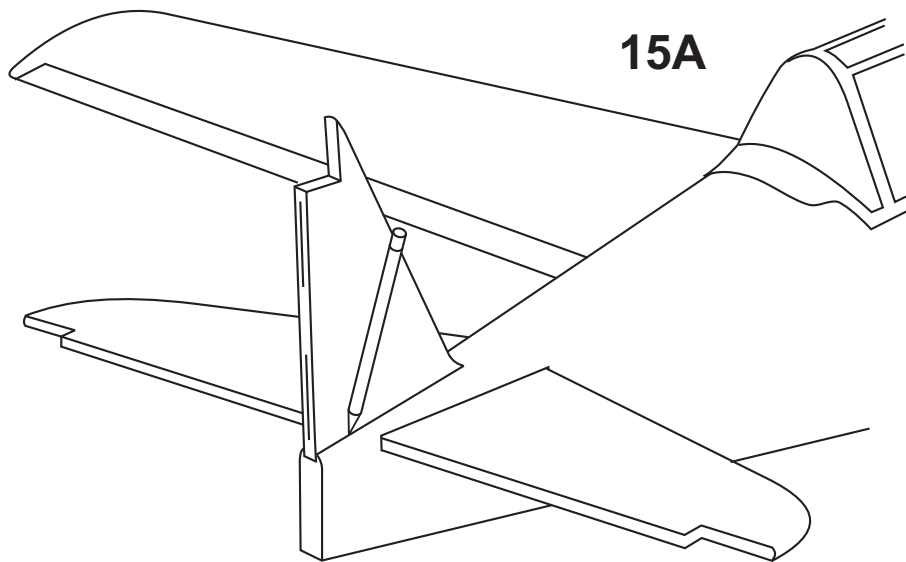
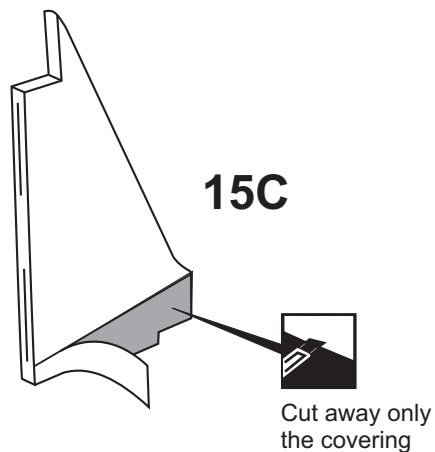
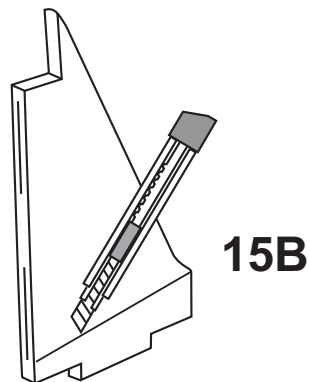

Trial fit the vertical fin in position. Using a 90 degree triangle, ensure that the vertical stabilizer is perpendicular to the horizontal stabilizer.

Apply the thin CA glue on the vertical stabilizer where it contacts the fuselage.

Wirraway 16- Elevator & control horn

Push the elevator and its hinges into the hinge slots in the trailing edge of the horizontal stabilizer. There should be a minimal hinge gap and the end of the elevator should not rub against the horizontal stabilizer.

When satisfied with the alignment, hinge the elevator to the horizontal stabilizer using thin CA glue.

Make sure to apply a thin layer of CA glue to the top and bottom of both hinges and to inside the hinge slots. Repeat the previous procedures to hinge the second elevator to the other side of the horizontal stabilizer.

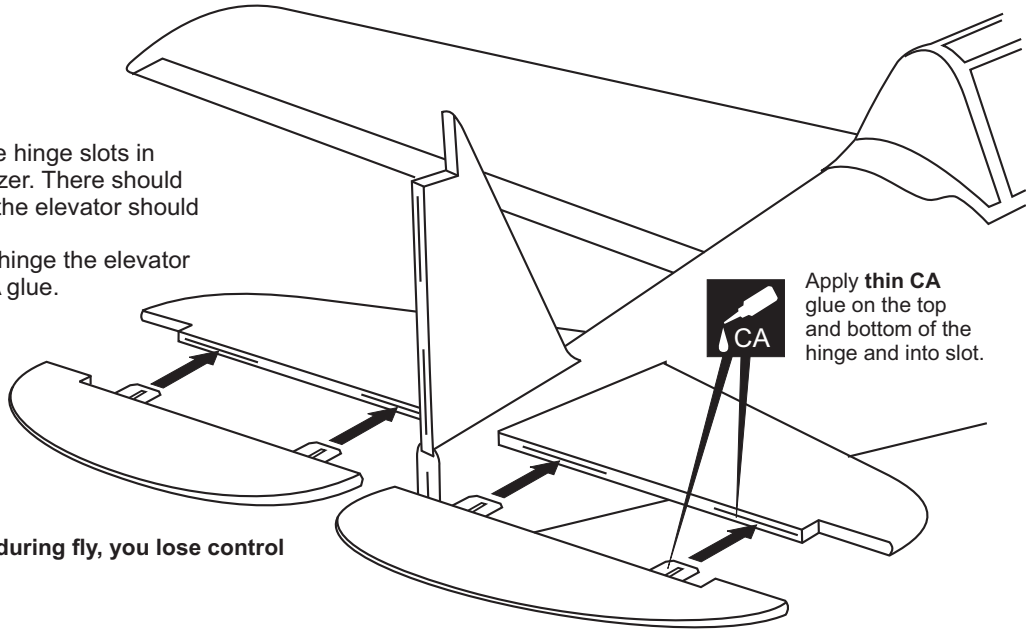

! Securely glue together. If coming off during fly, you lose control of your air plane.

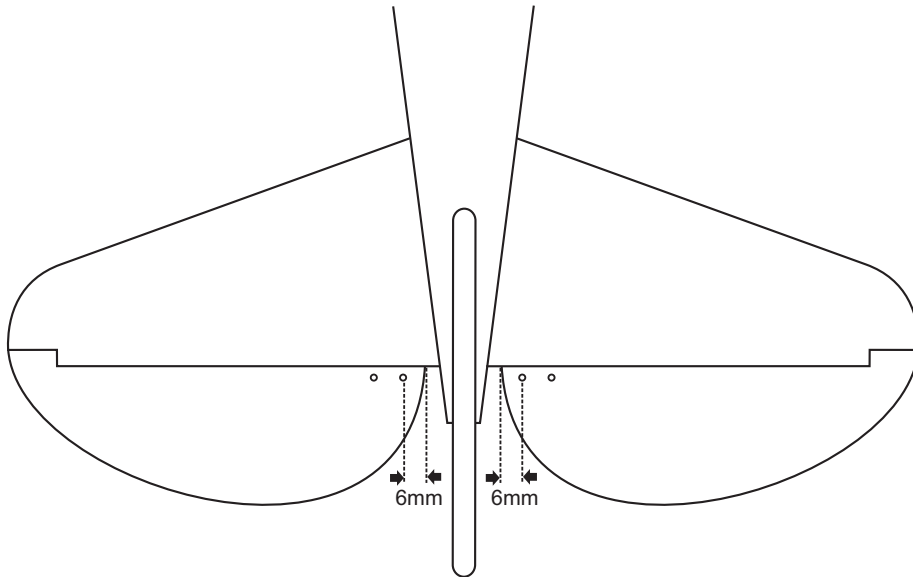

Control horn2
2x20mm screw4

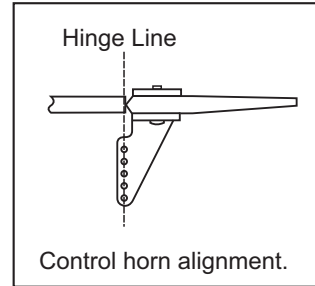

Using a control horn as a template, mark the elevator where the two holes to be drilled.

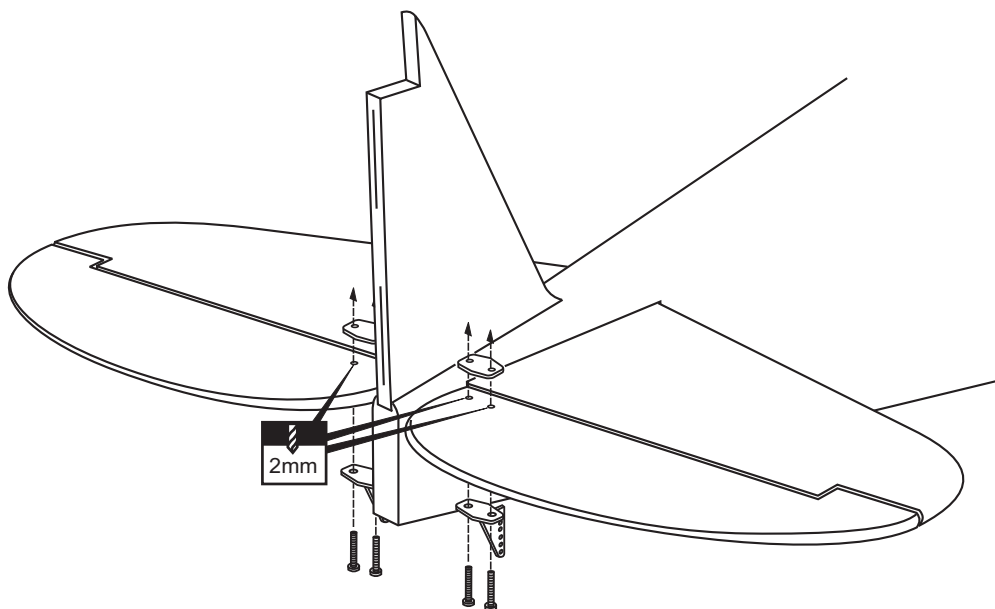

Wirraway 17- Rudder & control horn

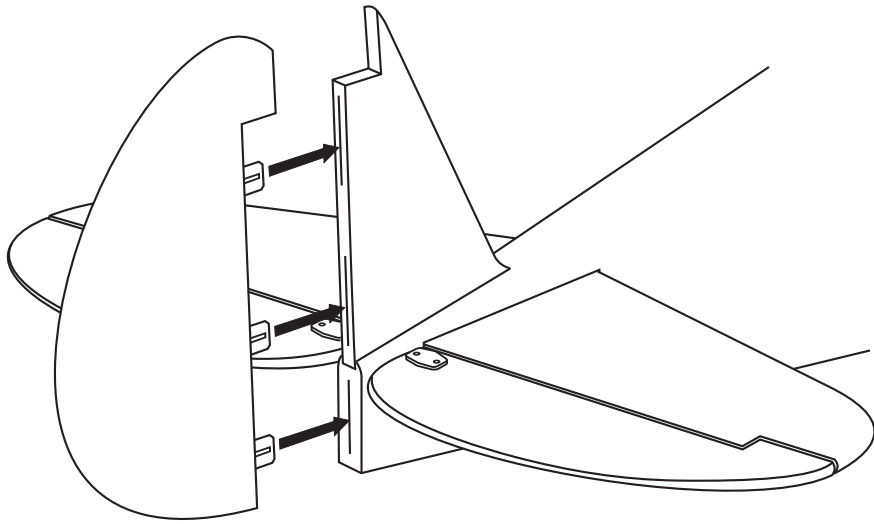

! Securely glue together. If coming off during fly, you lose control of your air plane.

Control horn

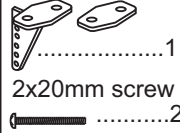

Using a control horn as a template, mark the rudder where the two holes to be drilled.

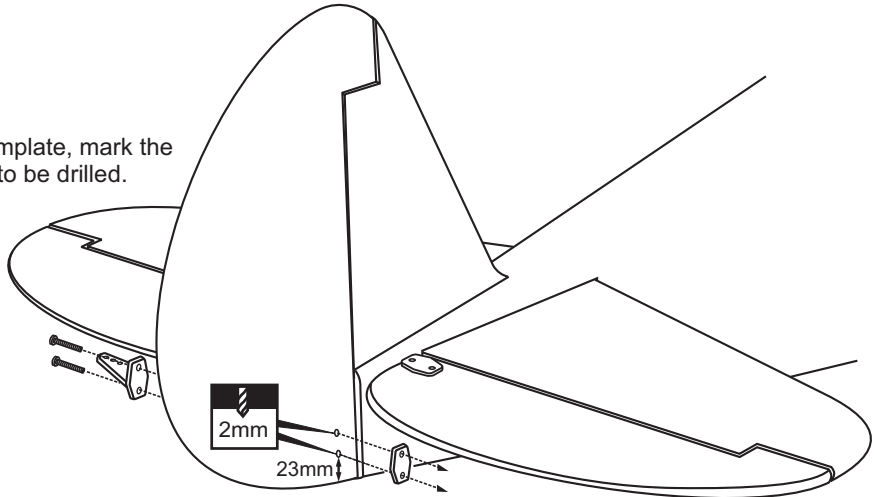

Hinge Line

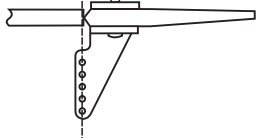

Control horn alignment.

Wirraway 18- Tail wheel

- 1-Place the tail gear mount on the bottom of the fuselage as show, mark the mounting hole positions with a pencil.
- 2-Remove the tail gear mount from the fuselage, Drill the two mounting holes as marked.
- 3-Slide the tail gear into the tail gear horn. Secure the tail gear mount in place using the two 3x12mm screw.

- 3x12mm screw
2
Tail gear horn
1
2x15mm bolt
1
2mm collar
2

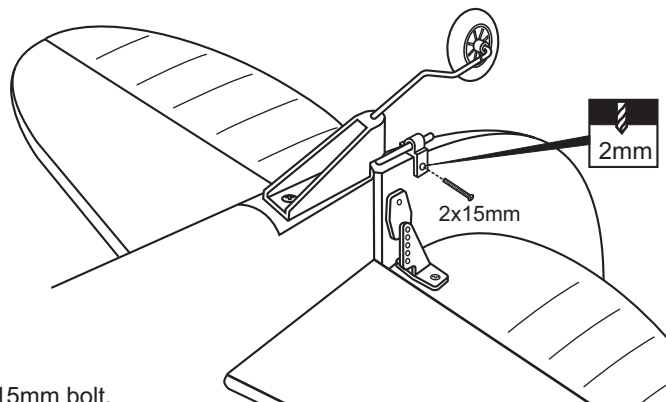
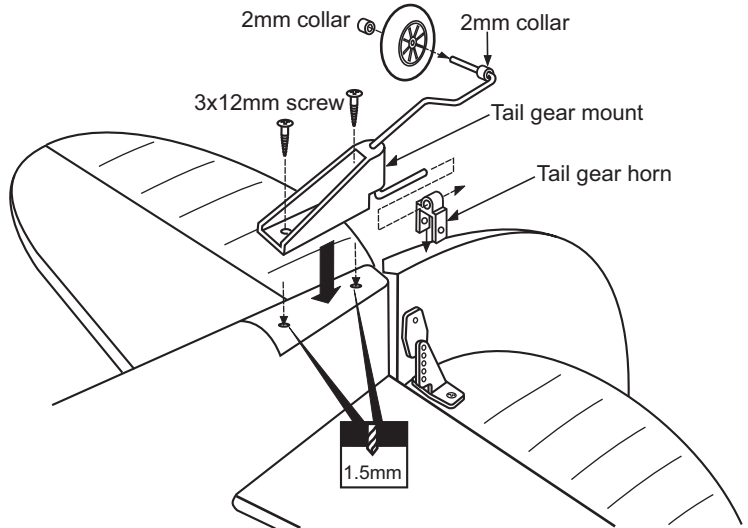

- 4- Secure the tail gear horn in place using 2x15mm bolt.

Wirraway 19- Engine mount

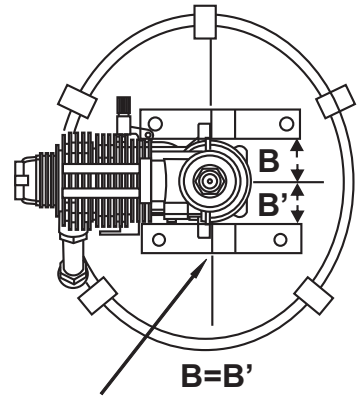
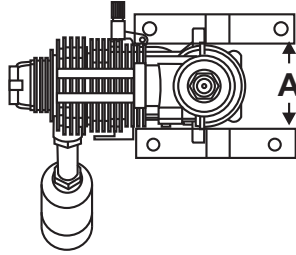
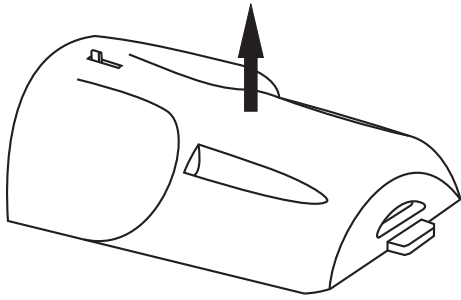

! Align the mark on both mounts with the mark on the fire-wall.

! Align the mark on both mounts with the mark on the fire-wall.

Using a pencil or felt tipped pen, mark the fire wall where the four holes are to be drilled.

NOTE:

! Engine thrust on bulkhead is already adjust at factory.

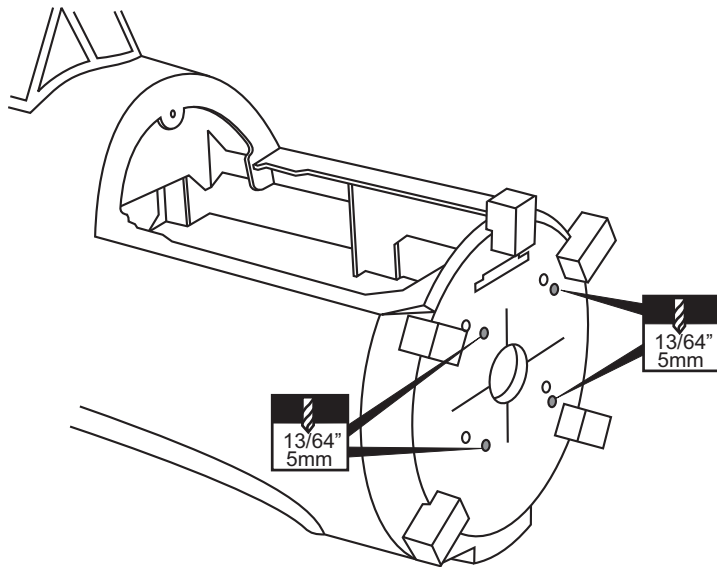
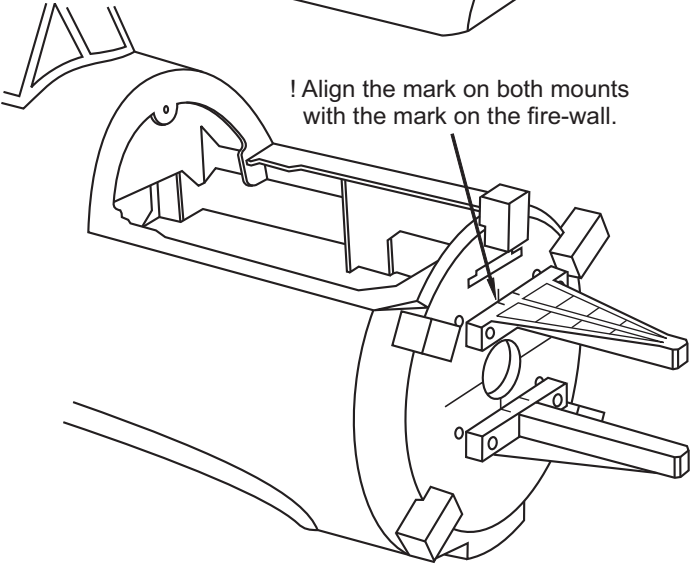

Remove the engine mount and drill a 3/16" (5mm) hole through the fire-wall at each of the four marks made above.

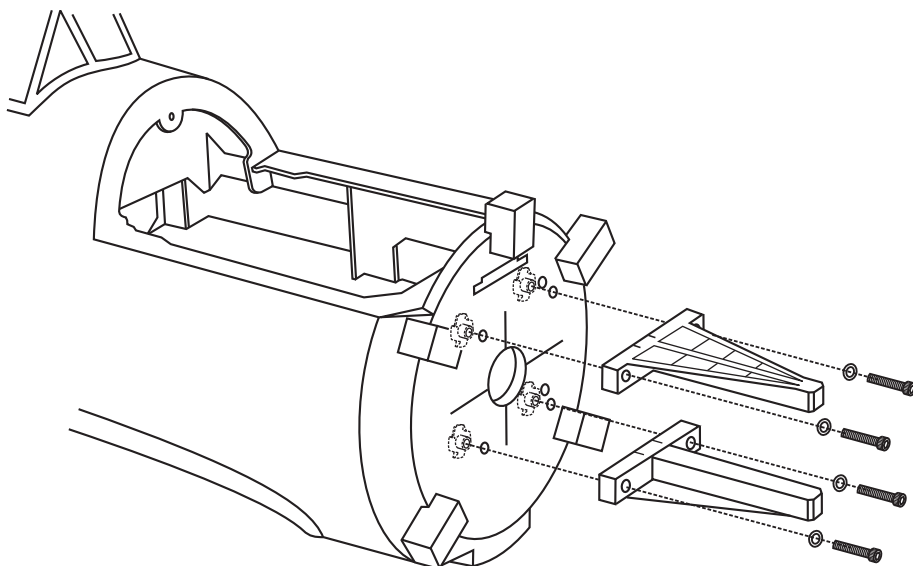

Attach the four blind-nuts to the fire-wall as show.

Reposition the engine mounts on to the fire-wall and secure them with four 5/32X1" (4x25mm) hex bold.

- 4x25mm hex bolt4
- Blind-nut4
- 4mm washer4
-4



Reposition the engine on the engine mount beams so the distance from the prop hub to the fire wall is 3.9"(100mm).

Mark the engine mounting plate where the four holes are to be drilled.
 Note: Mark the mounting plate through the engine mounting flanges.

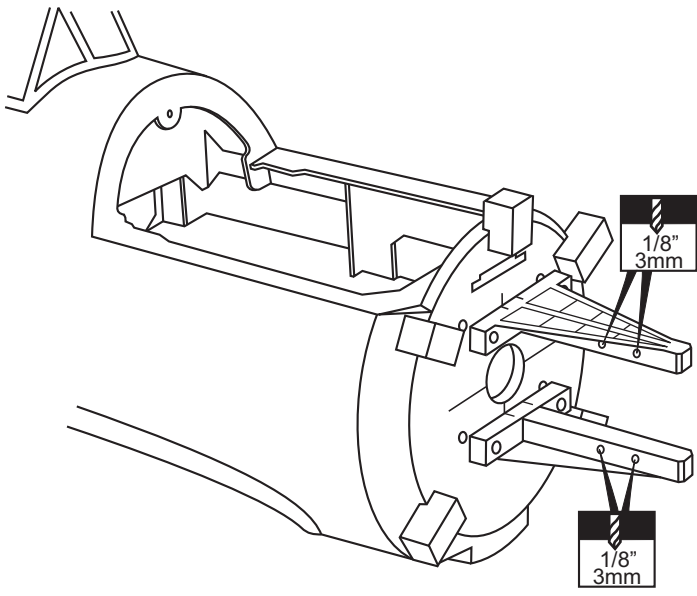

Remove the engine and drill a 1/8"(3mm) holes through the beam at each of the four marks made above.

Note: The drill bit must be perpendicular to the beam.

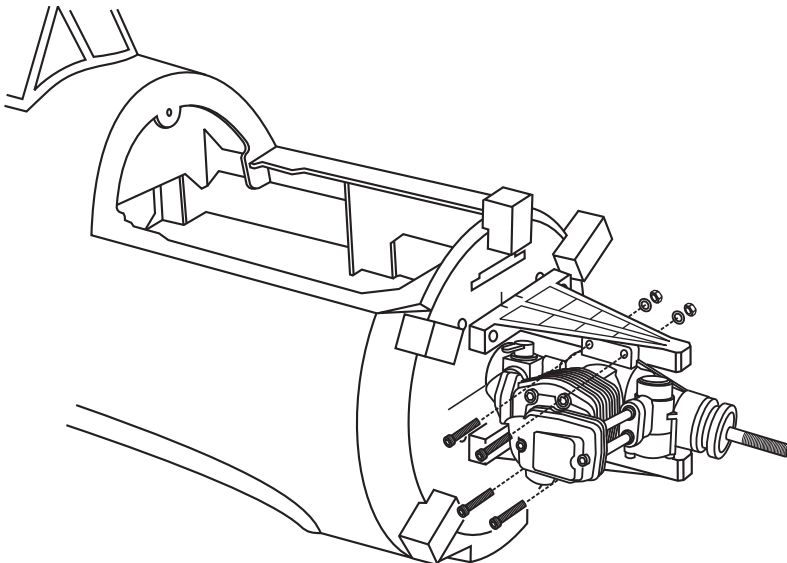

Reposition the engine on the engine mount beams, aligning it with the holes. Secure the engine to the engine mount using four 1/8x5/16"(3x25mm) hex-bolts, washers and nuts.

3x20mm hex bolt4
3mm nut4
3mm washer4

Wirraway 21- Fuel tank

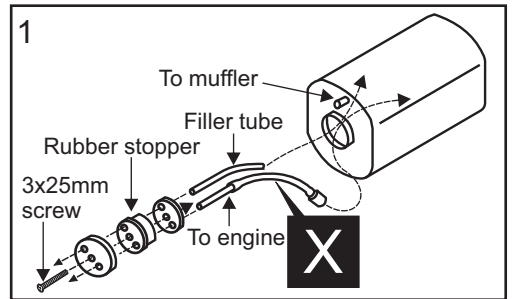
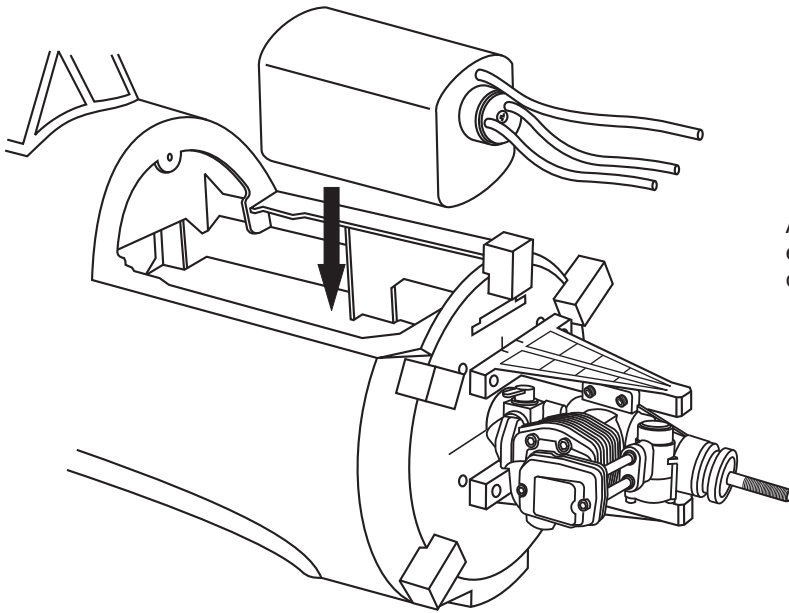

After confirming the direction . Insert this assembly, clunk end first, into the fuel tank and tighten and screw the fuel tank cap on firmly.

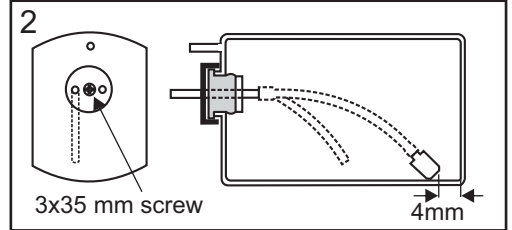

Checking for leaks - block the vents and blow into the feed if in doubt submersing the tank in a blow of water will show up any problems.

Wirraway 22- Electric motor mount installation

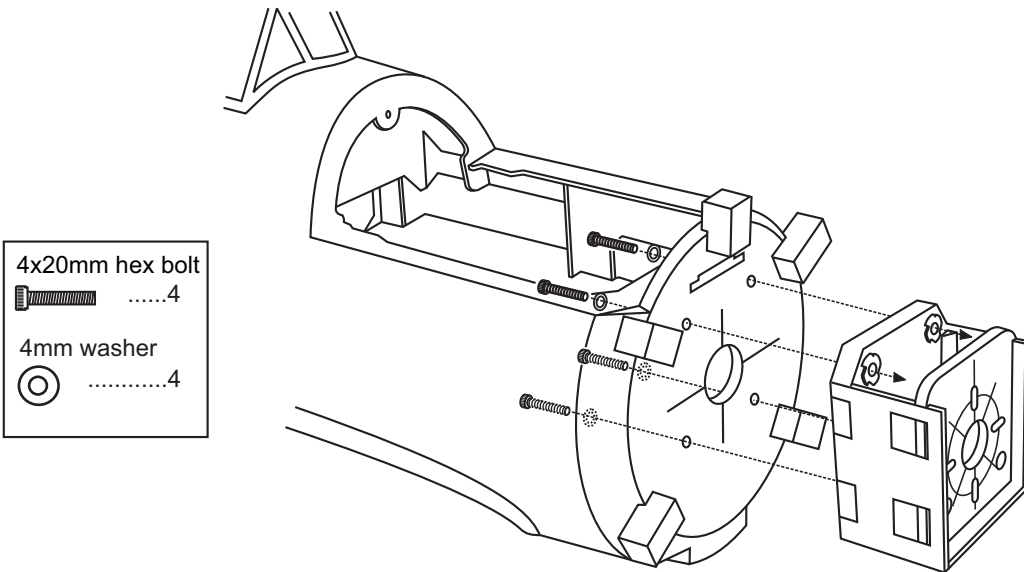

4x20mm hex bolt

.....4

4mm washer

.....4

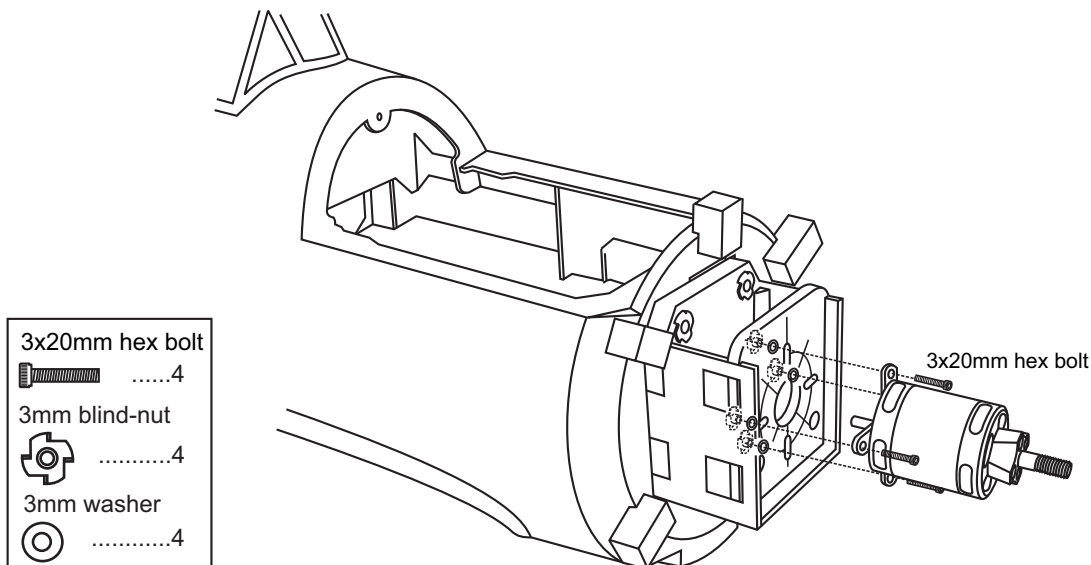

3x20mm hex bolt

.....4

3mm blind-nut

.....4

3mm washer

.....4

3x20mm hex bolt

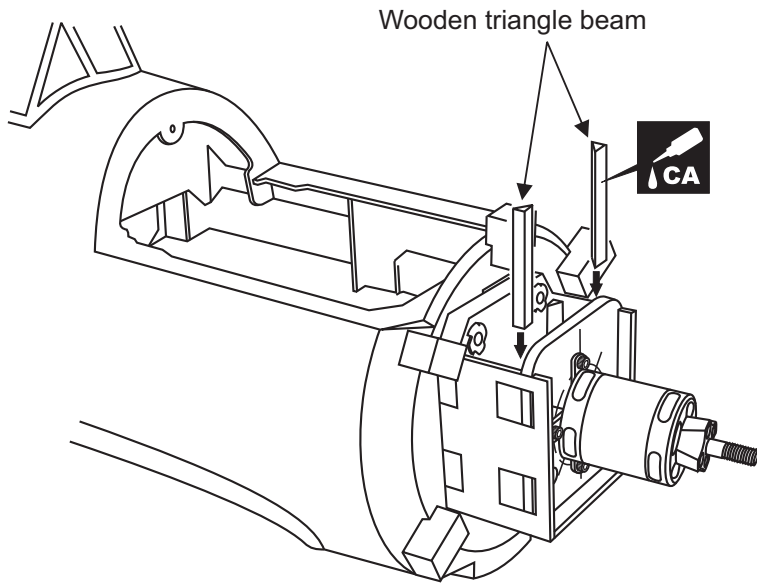
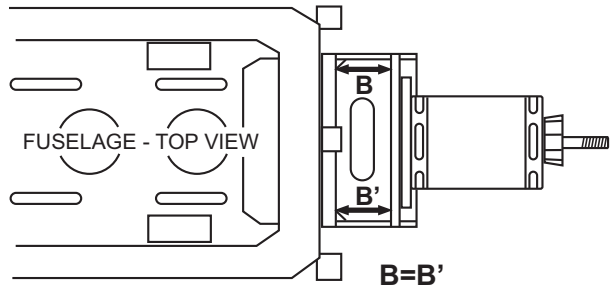
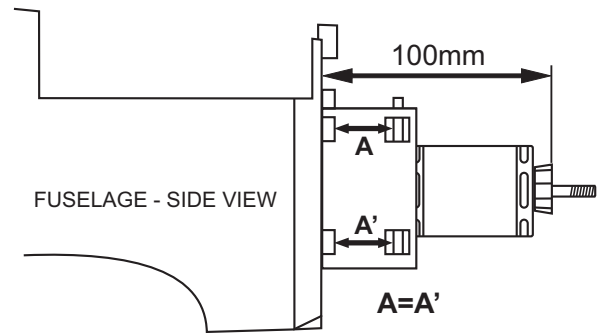
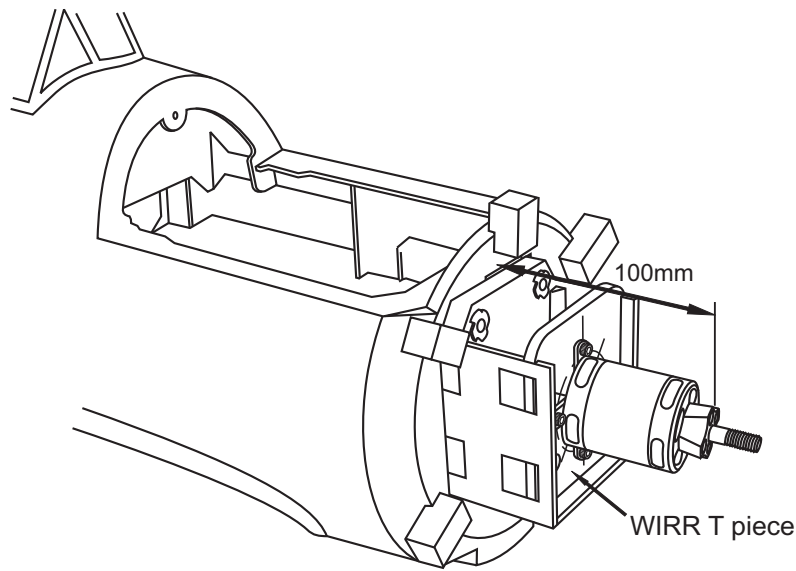

Move the WIRR T piece until the distance between the fire-wall and propeller hub is 100mm.
Secure the WIRR T in place with CA glue and two wooden triangle beams as shown.



IMPORTANT:

Before glue, you must make sure that the distance $A=A'$ and $B=B'$ are as shown in the pictures.

NOTE:

! Engine thrust on bulkhead is already adjust at factory.

Wirraway 24- Linkages

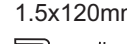
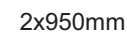
- Connector  2
- Connector  1
- 1.2x500mm throttle rod  1
- 1.5x120mm Elev. rod  1
- 2x950mm rod  3

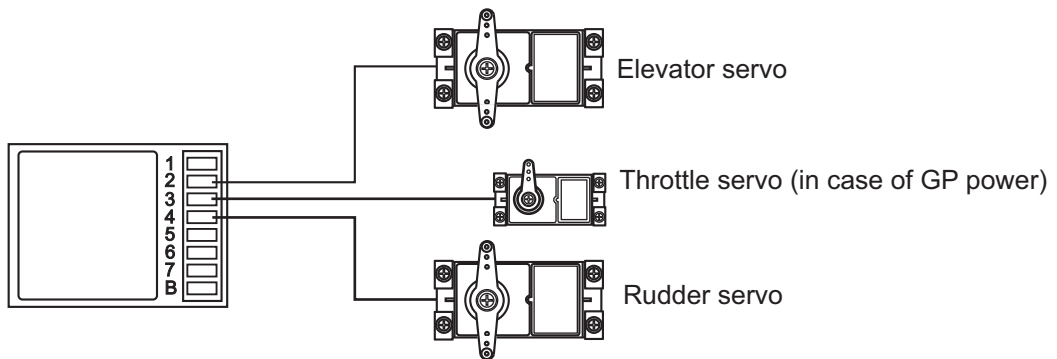
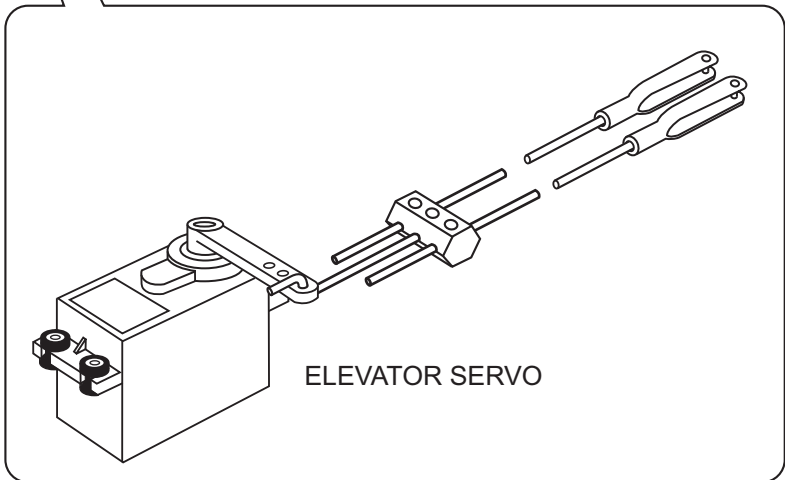
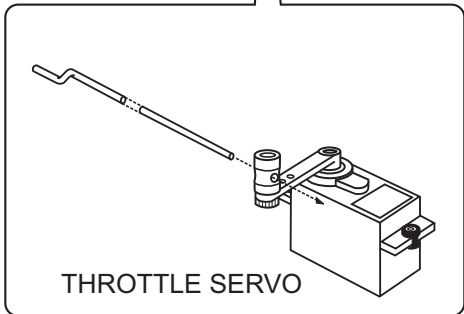
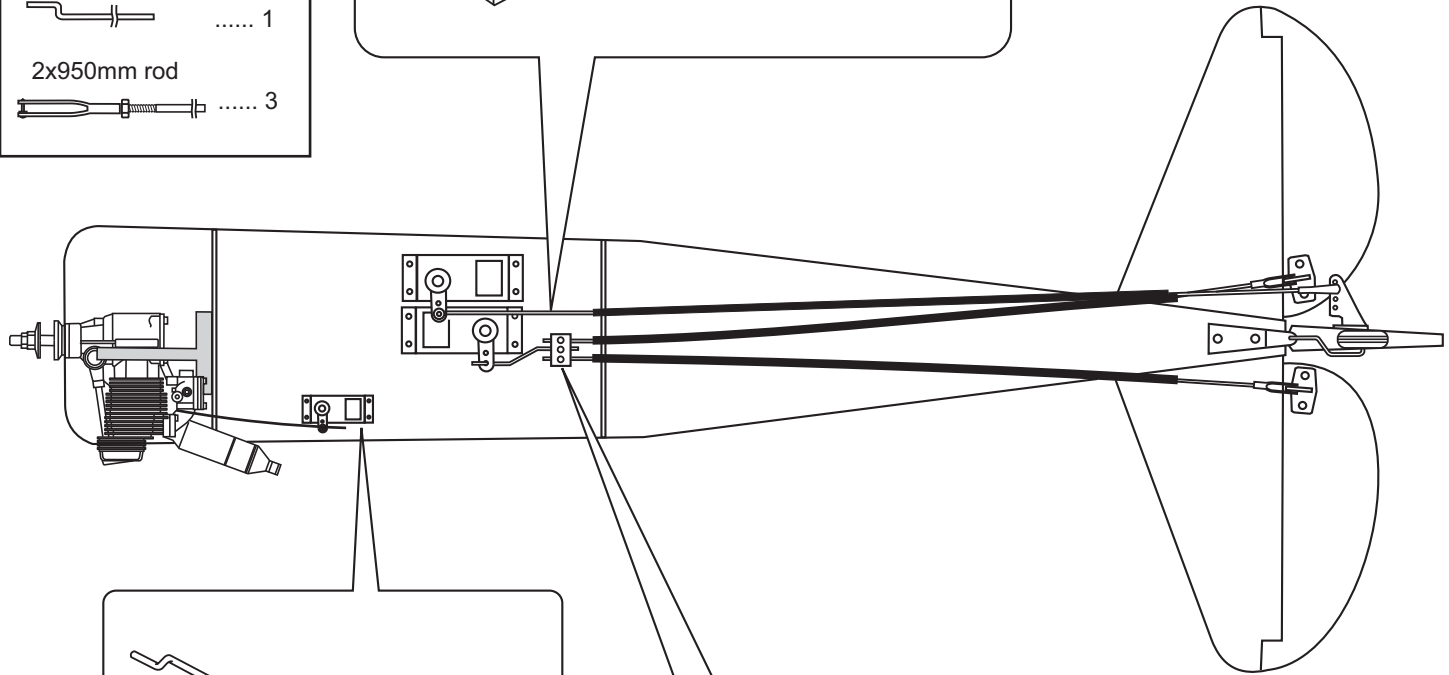
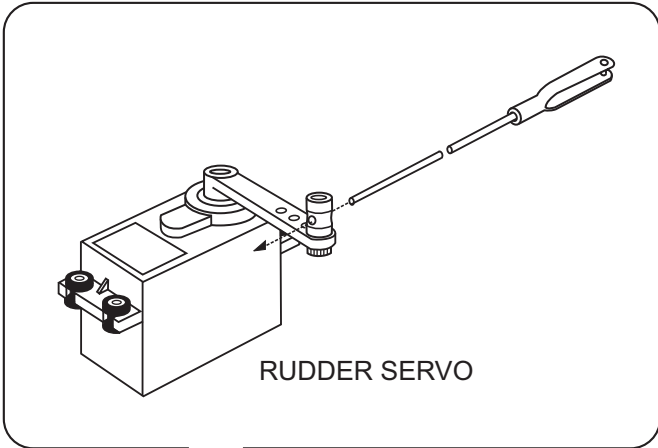

Wirraway 25- Dummy engine and air scoop

15 min. **A B**

Cut out the dark areas to cool the engine.

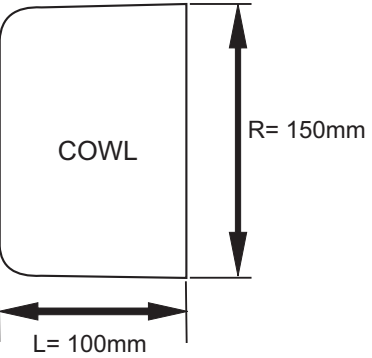
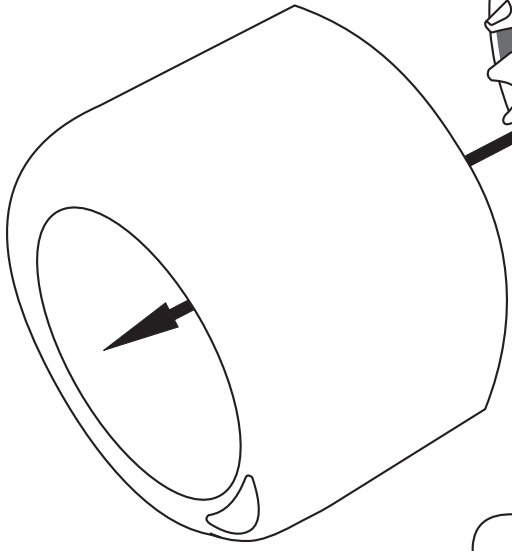
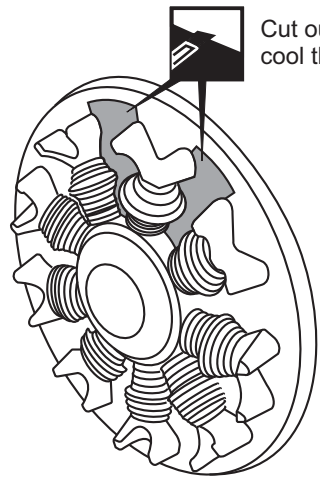

Insert the cowl on to the fuselage and secure it in place with four 2.5x10mm self tapping screws.

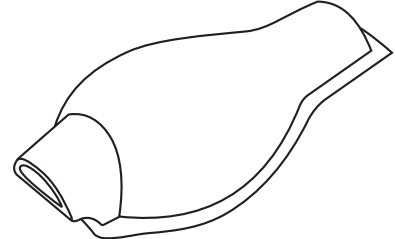
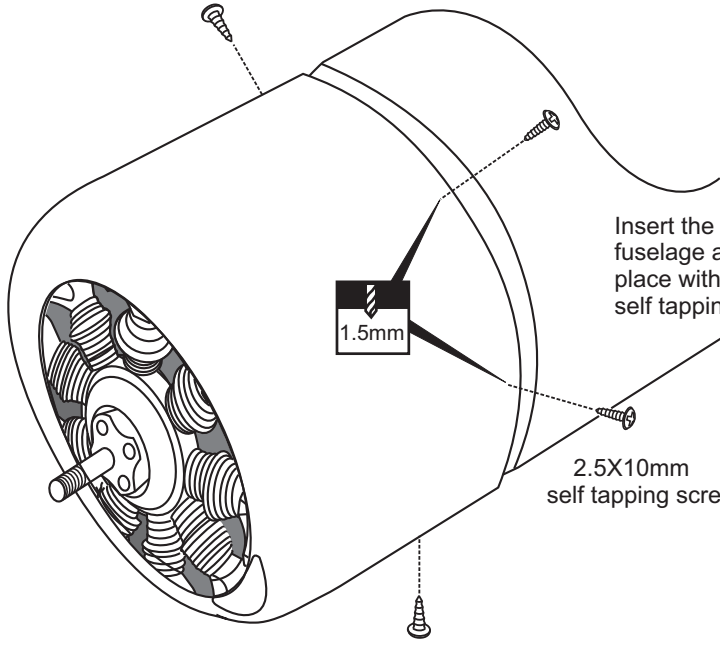

2X6mm self tapping screw

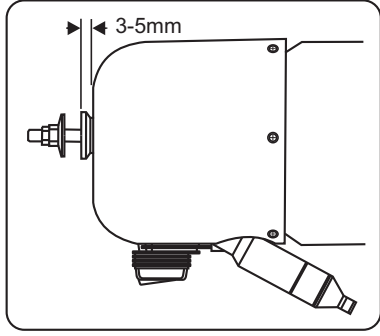
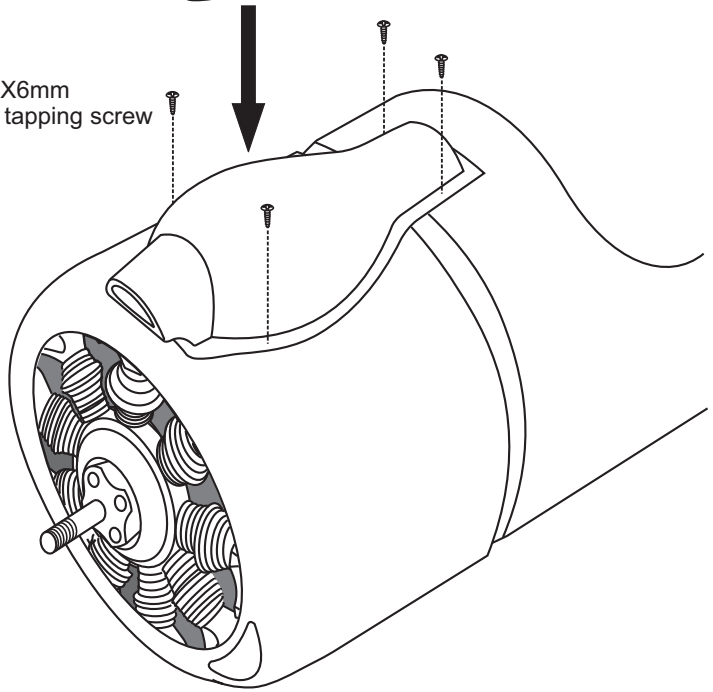

- 2.5x10mm screw
- 5
- 2x6mm screw
- 4

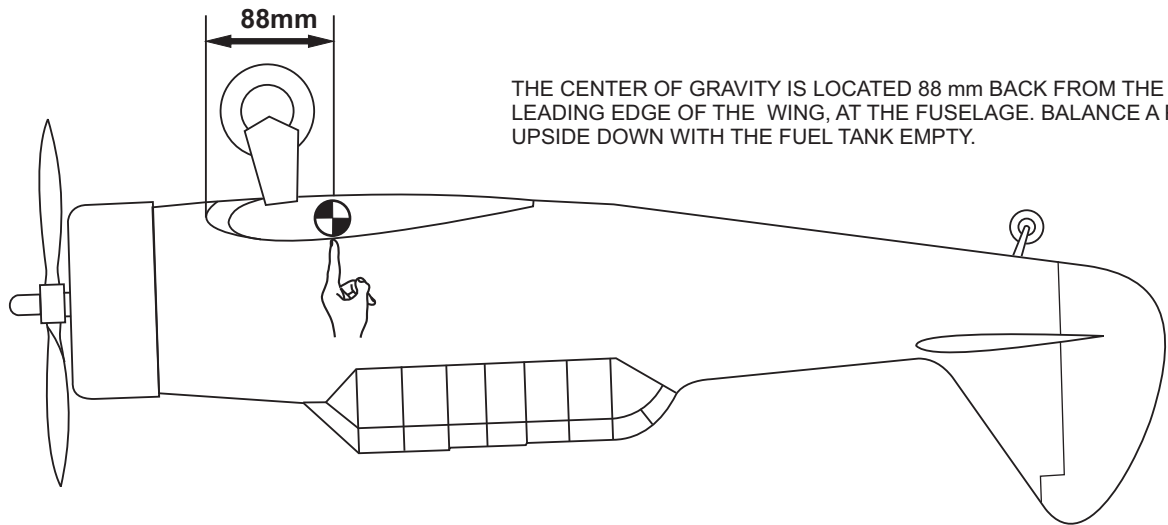

THE CENTER OF GRAVITY IS LOCATED 88 mm BACK FROM THE LEADING EDGE OF THE WING, AT THE FUSELAGE. BALANCE A PLANE UPSIDE DOWN WITH THE FUEL TANK EMPTY.

- 1- Mount the wing to the fuselage. Using a couple of pieces of masking tape, place them on the top side of the wing (88mm) back from the leading edge, at the fuselage sides.
- 2- Lift the airplane. Place your fingers on the masking tape and carefully lift the plane.

3- If the nose of the plane falls, the plane is heavy nose. To correct this, move the battery pack further back in the fuselage. If the tail of plane falls, the plane is tail heavy. To correct this, move the battery forward or if this is not possible, stick weight onto the firewall. When balanced correctly, the airplane should level or slightly nose down when you lift it up with your fingers.

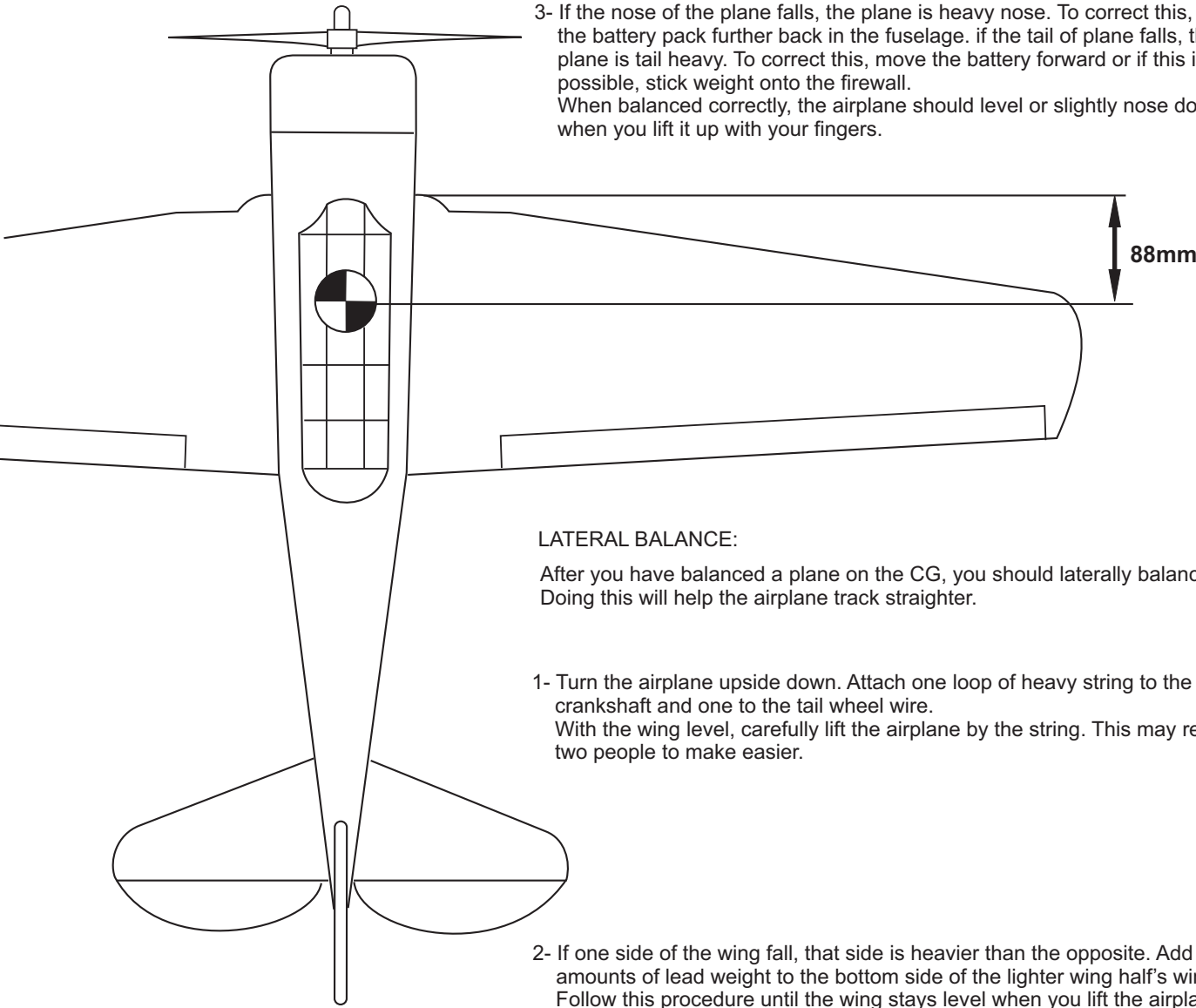

LATERAL BALANCE:

After you have balanced a plane on the CG, you should laterally balance it. Doing this will help the airplane track straighter.

- 1- Turn the airplane upside down. Attach one loop of heavy string to the engine crankshaft and one to the tail wheel wire. With the wing level, carefully lift the airplane by the string. This may require two people to make easier.
- 2- If one side of the wing fall, that side is heavier than the opposite. Add small amounts of lead weight to the bottom side of the lighter wing half's wing tip. Follow this procedure until the wing stays level when you lift the airplane.



DO NOT try to fly an out-of-balance model !

Wirraway 26- How to add noseweight

To get the correct C.G., Several strips of lead weight were required in the nose of this model . To minimize the amount of weight required, it is desirable to position the weight as far forward as possible. This can be done by making a platform form left over basswood stick and 3mm ply wood. Using 3x35mm bolts to mount the engine would also be long enough to mount the flat form. The lead should be permanently glued on with epoxy.

IMPORTANT: Recheck the C.G. After the weight has been installed.

ATTENTION:

The weight of lead added to the nose is about 300gr to 400gr depending on the position of the lead and the type of engine you use.

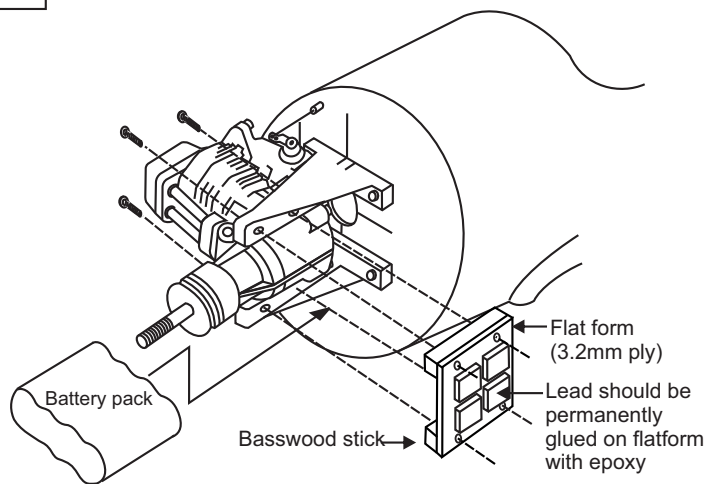

Wirraway 27- Decor

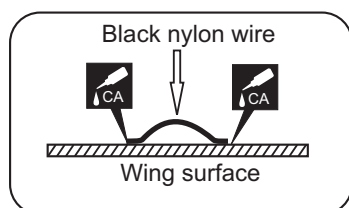

Do the same way with other wing.

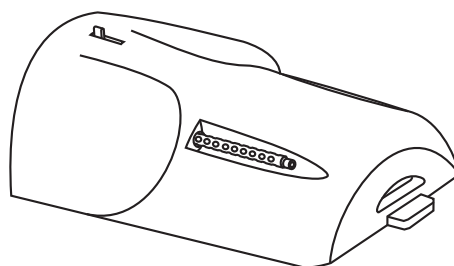
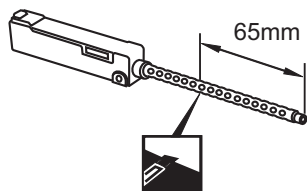
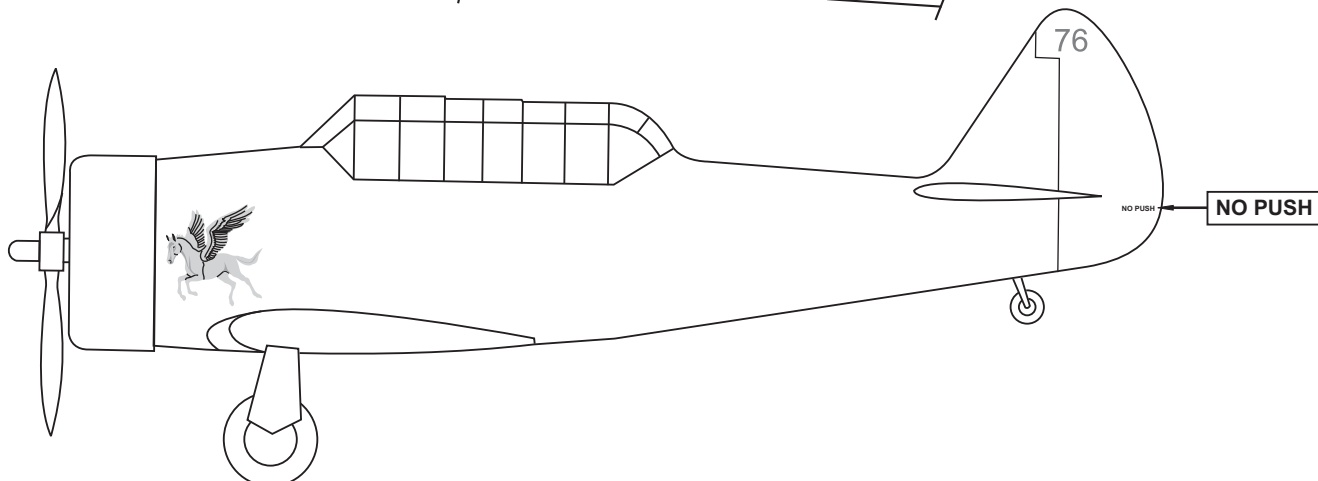
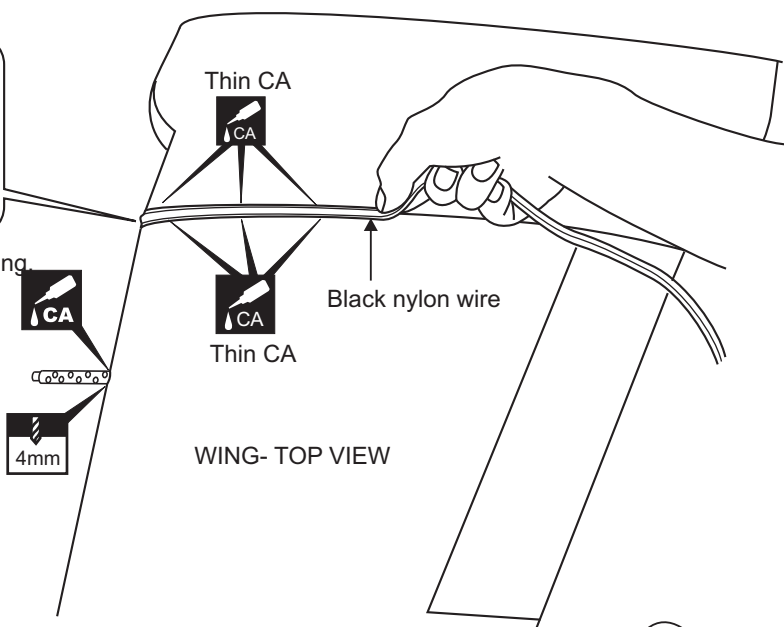

Wirraway 28- Decor

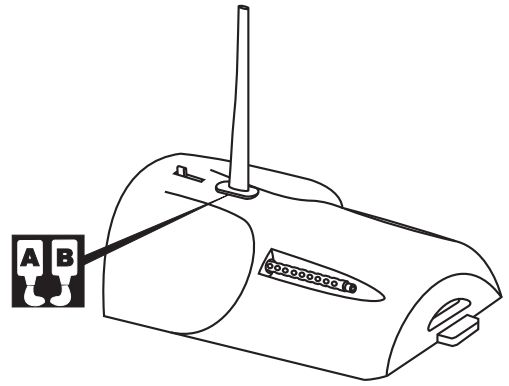
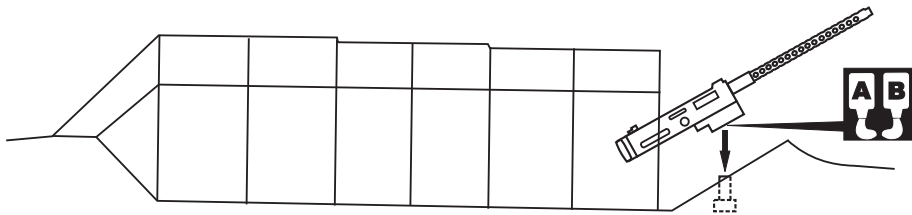

Wirraway 29- Control surface

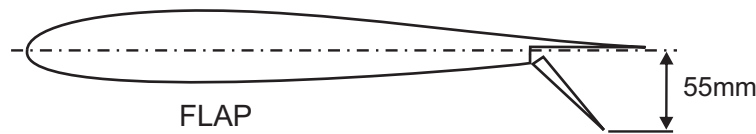
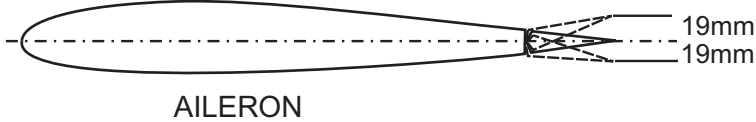

ATTENTION:

When you lower the flap, you must mix the flap with the elevator.
When the flap is lowered to its lowest position, the elevator must be lowered 2mm from its normal position.

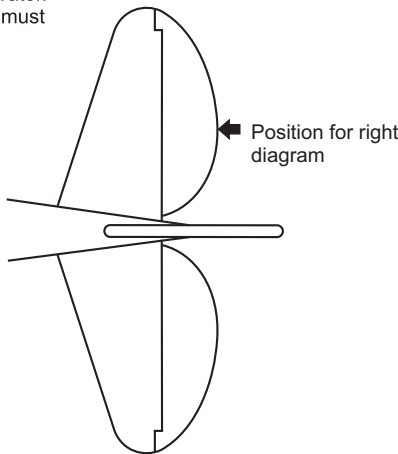
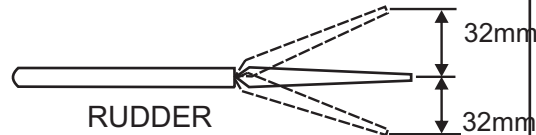
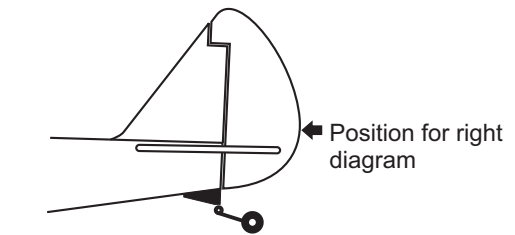
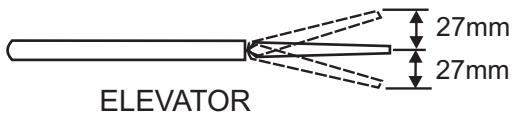

LOW RATE

Aileron	: 15mm up / down
Elevator	: 22mm up / down
Rudder	: 20mm right / left
Flap	: 40mm down

HIGH RATE

Aileron	: 19mm up / down
Elevator	: 27mm up / down
Rudder	: 32mm right / left
Flap	: 55mm down



IMPORTANT: Flying your model at these throws will provide you with the greatest chance for successful first flights. If, after you have become accustomed to the way the Wirraway flies, you would like to change the throws to suit your taste that is fine. However, too much control throw could make the model difficult to control, so remember, "more is not always better".