

# RADIO CONTROL MODEL

# CURTISS P-40

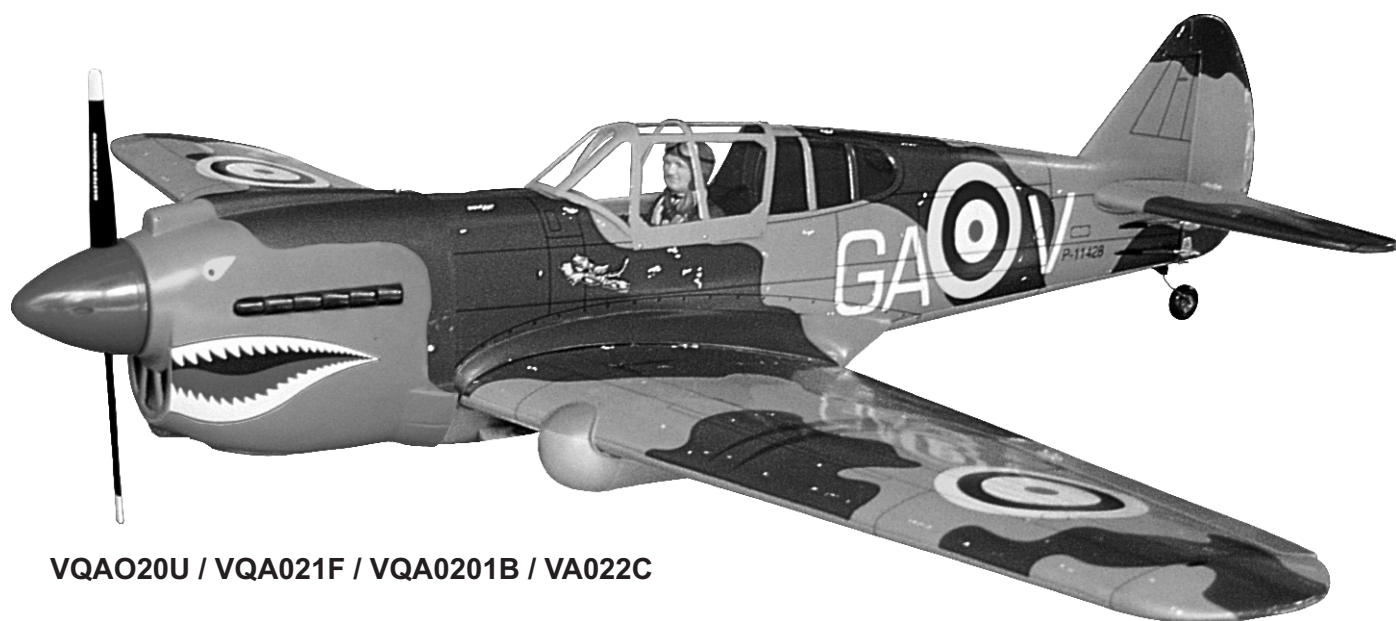

VQAO20U / VQA021F / VQA0201B / VA022C

## INSTRUCTION MANUAL / MONTAGEANLEITUNG

### TECHNISCHE DATEN

Spannweite	1570mm
Länge	1360mm
Elektroantrieb	870 Watt Brushless Motor
Verbrennerantrieb	10cc 2-T / 15cc 4-T
Fernsteuerung	6 Kanal / 7 Servos

### SPECIFICATIONS

Wingspan	1570mm
Length	1360mm
Electric Motor	870 Watt Brushless Motor
Glow Engine	.60 2-T / .90 4-T
Radio	6 Channel / 7 Servos

**WARNING!** This radio controlled model is NOT a toy. If modified or flown carelessly it could go out of control and cause serious human injury or property damage. Before flying your airplane, ensure the air field is spacious enough. Always fly it outdoors in safe areas and seek professional advice if you are unexperienced.

**ACHTUNG!** Dieses ferngesteuerte Modell ist KEIN Spielzeug! Es ist für fortgeschrittene Modellflugpiloten bestimmt, die ausreichende Erfahrung im Umgang mit derartigen Modellen besitzen. Bei unsachgemäßer Verwendung kann hoher Personen- und/oder Sachschaden entstehen. Fragen Sie in einem Modellbauverein in Ihrer Nähe um professionelle Unterstützung, wenn Sie Hilfe im Bau und Betrieb benötigen. Der Zusammenbau dieses Modells ist durch die vielen Abbildungen selbsterklärend und ist für fortgeschrittene, erfahrene Modellbauer bestimmt.



# REQUIRED FOR OPERATION (Purchase separately) BENÖTIGTE KOMPONENTEN FÜR DEN ABFLUG (Nicht enthalten)

12x6 for .60 - 2 cycle engine  
13x7 for .90 - 4 cycle engine  
14x8 for Quantum 4120/07  
BOOTS 60

Phoenix-60 Brushless Motor Control or equivalent.

Extension for aileron Flap and retract servo. Retract landing gear VQAR07

Retract servo x1

Linkage Stopper x2 (for retract servo)

Brushless Motor BOOST 60

Li-Po Battery, 14.8V, 4500mAH (25C)

Minimum 6 channel radio for airplane with 7 servos  
(Motor control x1) .Aileron x2  
.Elevator x1 .Rudder x1  
.Flap x 2

.60 - 2 cycle

.90 - 4 cycle

Silicone tube

## GLUE (Purchase separately)

Silicon sealer

Cyanoacrylate Glue  
Klebstoff

CA

EPOXY A

Epoxy Glue (5 minute type)  
Epoxy-Klebstoff (5min-Typ)

EPOXY B

Epoxy Glue (30 minute type)  
Epoxy-Klebstoff (30min-Typ)

## TOLLS REQUIRED (Purchase separately)

Hobby knife

Phillip screw driver

Hex Wrench

Needle nose Pliers

Scissors

Awl

Sander

Wire Cutters

Masking tape - Straight Edged Ruler - Pen or pencil - Rubbing alcohol - Drill and Assorted Drill Bits

If exposed to direct sunlight and/or heat, wrinkles can appear. Storing the model in a cool place will let the wrinkles disappear. Otherwise, remove wrinkles in covering film with a hair dryer, starting with low temperature. You can fix the corners by using a hot iron.

Bei Sonneneinstrahlung und/oder Wärme kann die Folie erschlaffen bzw. Falten entstehen. Verwenden Sie ein Warmluftgebläse (Haartrockner) um evtl. Falten aus der Folie zu bekommen. Die Kanten können Sie mit einem Bügeleisen behandeln. Nicht zuviel Hitze anwenden !

Low setting

Drill holes using the stated size of drill (in this case 1.5 mm Ø)	Take particular care here	Hatched-in areas: remove covering film carefully	Check during assembly that these parts move freely, without binding
Use epoxy glue	Apply cyano glue	Assemble left and right sides the same way.	Not included. These parts must be purchased separately

Löcher bohren mit dem angegebenen Bohrer (hier 1,5 mm)	Hier besonders aufpassen	Schraffierte Stellen, Bespannfolie vorsichtig entfernen	Während des Zusammenbaus immer prüfen, ob sich die Teile auch reibungslos bewegen lassen
Epoxy-Klebstoff verwenden	Sekundenkleber auftragen	Linke und rechte Seite wird gleichermaßen zusammgebaut	Nicht enthalten. Teile müssen separat gekauft werden.

Read through the manual before you begin, so you will have an overall idea of what to do.

### CONVERSION TABLE

1.0mm = 3/64"	3.0mm = 1/8"	10mm = 13/32"	25mm = 1"
1.5mm = 1/16"	4.0mm = 5/32"	12mm = 15/32"	30mm = 1-3/16"
2.0mm = 5/64"	5.0mm = 13/64"	15mm = 19/32"	45mm = 1-51/64"
2.5mm = 3/32"	6.0mm = 15/64"	20mm = 51/64"	

# 1- Joining the wing / Flächenverbindung

TOP VIEW / AUFSICHT

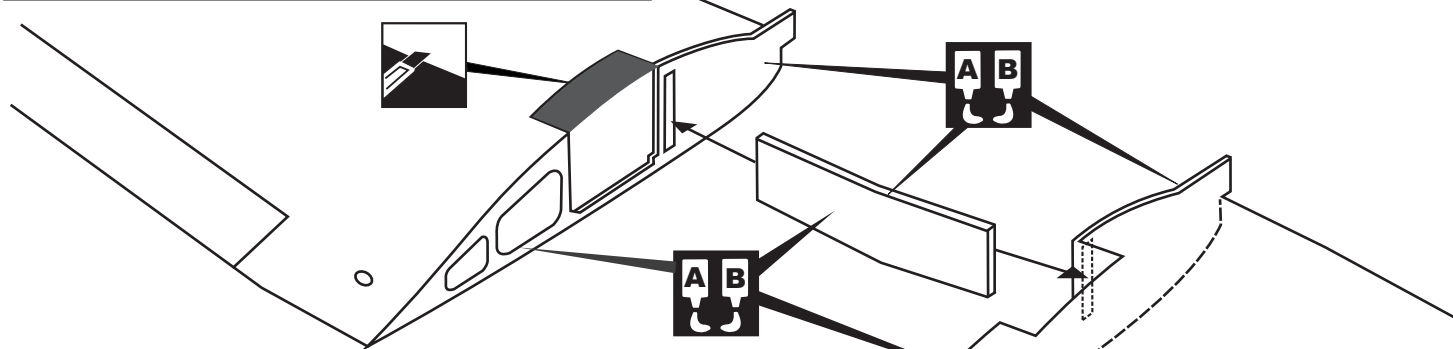

- 1- Using a pencil, mark the center of the brace.
- 2- Trial fit the wing joiner into one of the wing panels. It should insert smoothly up to the center line marked above.
- 3- Slide the other wing half onto the dihedral brace until the wing panel meet. If the fit is over tight, it may be necessary to lightly sand the dihedral brace.
- 4- Check for the correct dihedral angle.
- 5- Mix approximately 30 minute epoxy and apply a generous amount of epoxy into the wing joiner cavity of one wing half.
- 6- Coat one half of the dihedral brace with epoxy up to the center line. Install the epoxy-coated side of the dihedral brace into the wing joiner cavity up to the center line, marking sure that the "V" of the dihedral brace is positioned correctly
- 7- Do the same way with the other wing half.
- 8- Carefully slide the wing halves together, ensuring that they are accurately aligned. Firmly press the two halves together, allowing the excess epoxy to run out. Clear off the excess epoxy.

**IMPORTANT:** Please do not clean off the excess epoxy on the wing with strong solvent or pure alcohol, only use kerosene to keep the colour of your model not fade.

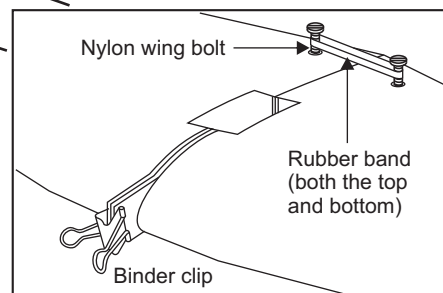

# 2- Retract Servo mount / Servoaufnahmen

Note:  
Retract servo mount "B" is longer than "C"

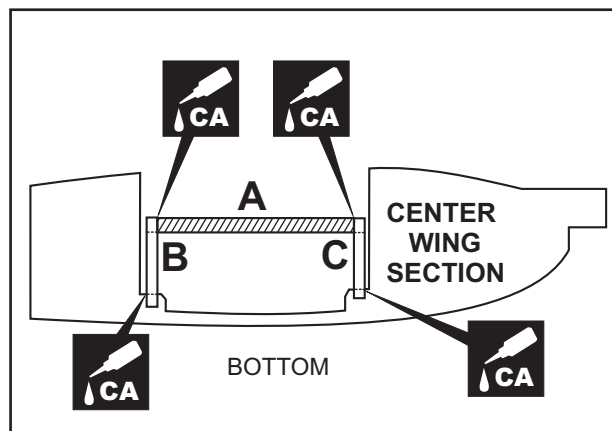
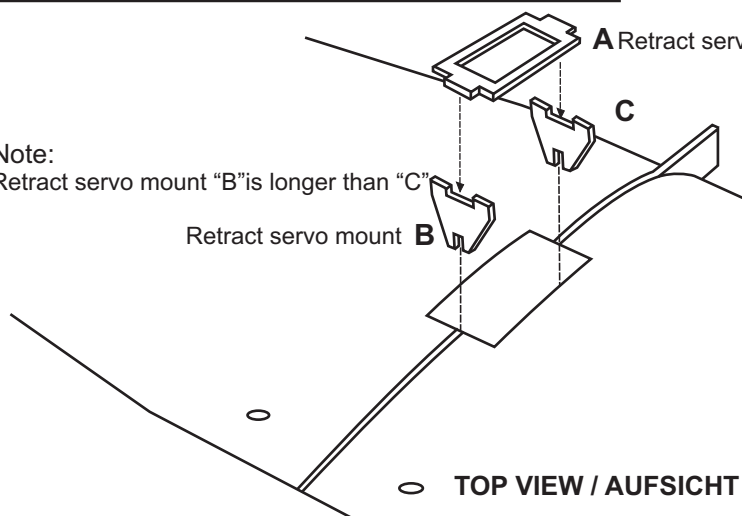

# 3- Retract servo / Einziehfahrwerk servo

Install the retract servo onto the retract servo mount and secure it in place with four screw (included with radio set).

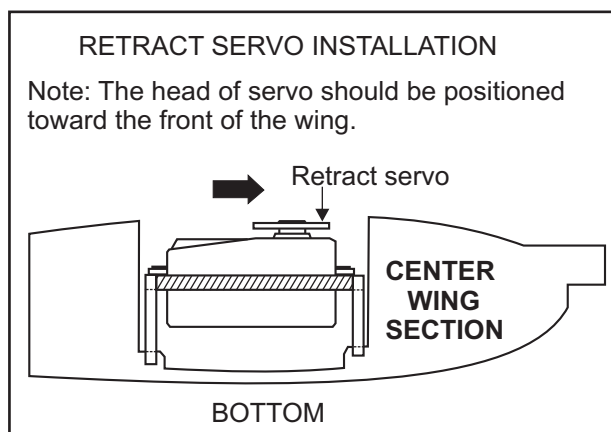
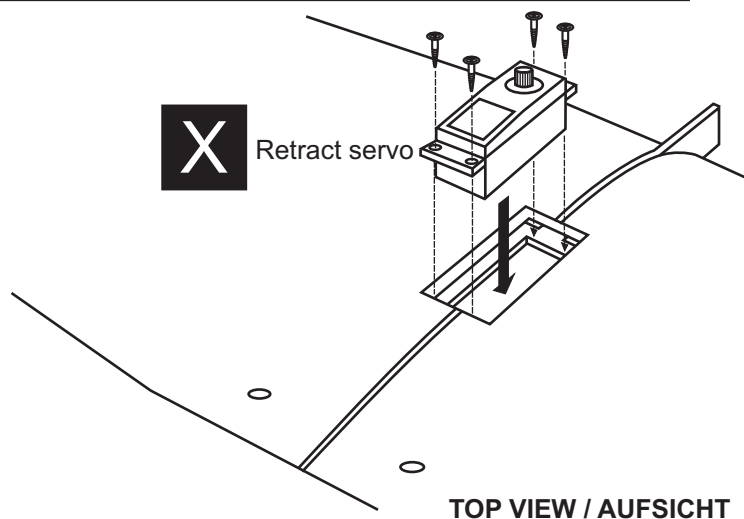

#### 4- Retract landing gear / Einziehfahrwerk

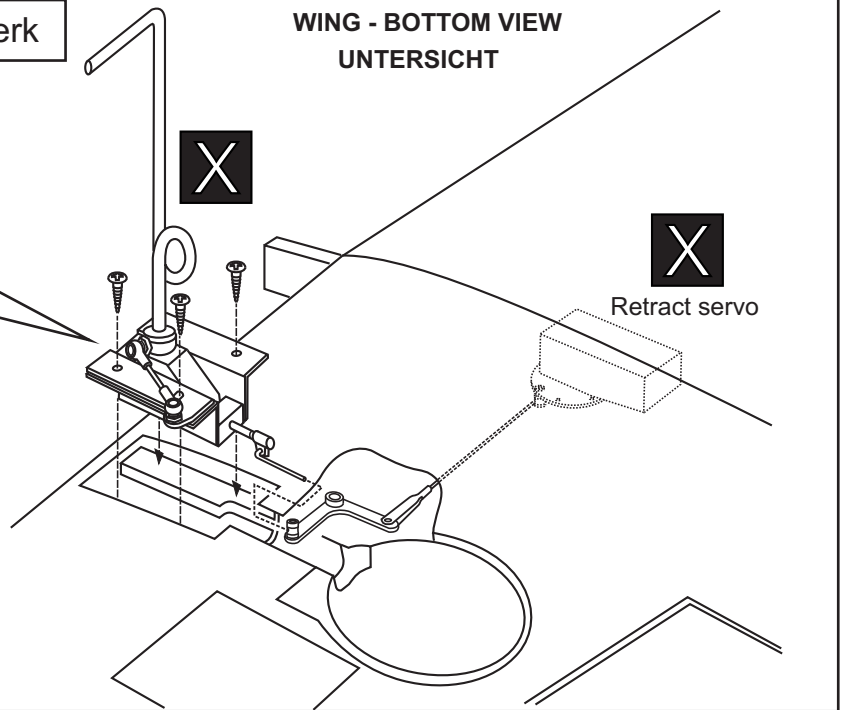
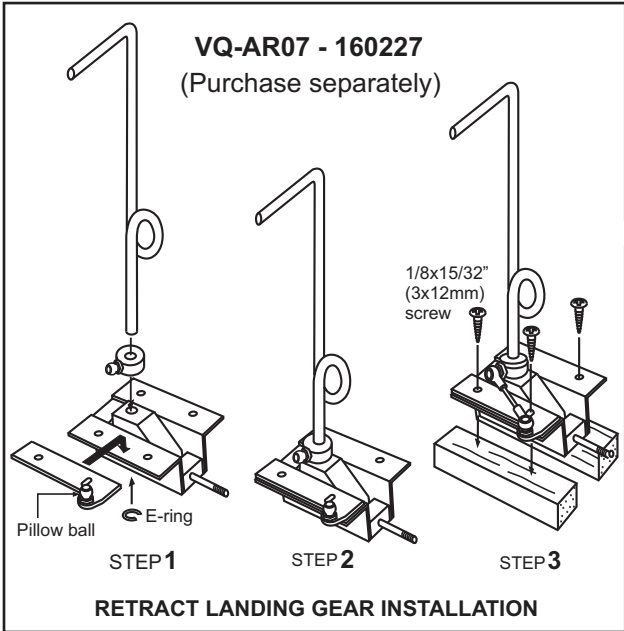

#### 5- Fixed gear / Starres Fahrwerk

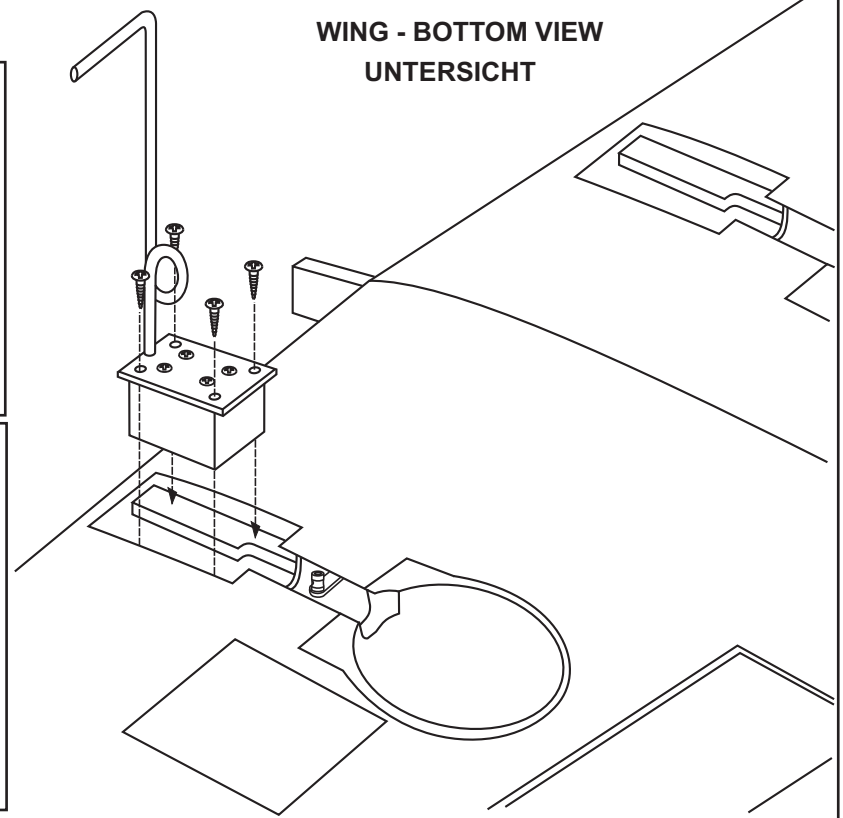
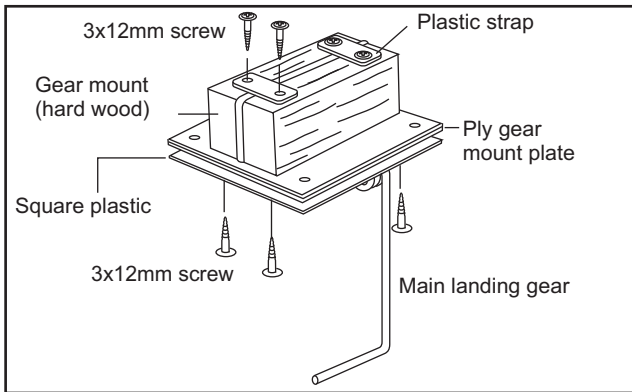
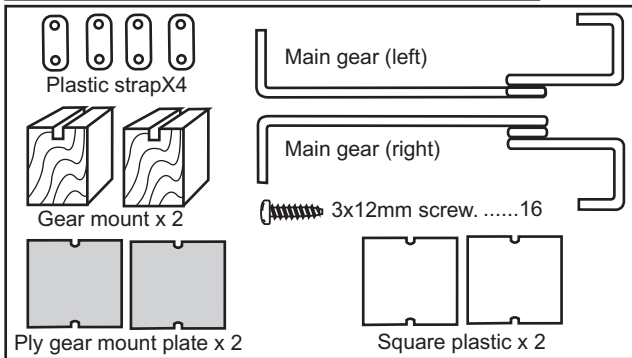

#### 6- ABS Shield

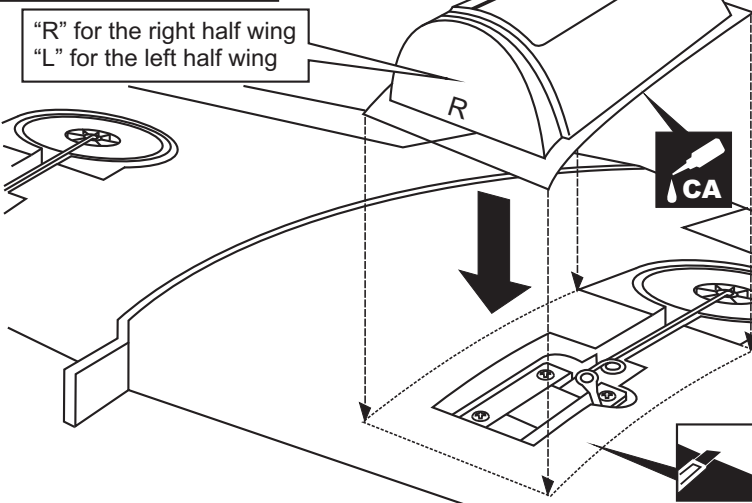

- 1-Using the ABS retract shield as a template, trace around the outside edge of the ABS retract shield, and then remove it.
- 2-Using a sharp hobby knife, cut away the covering inside the lines. Not to cut into the wood.
- 3-Apply the ABS retract shield in place and secure with CA glue.

**WING - BOTTOM VIEW**  
**UNTERSICHT**

Cut away only the film inside the line.

# 7- ABS Shield

WING - BOTTOM VIEW  
UNTERSICHT

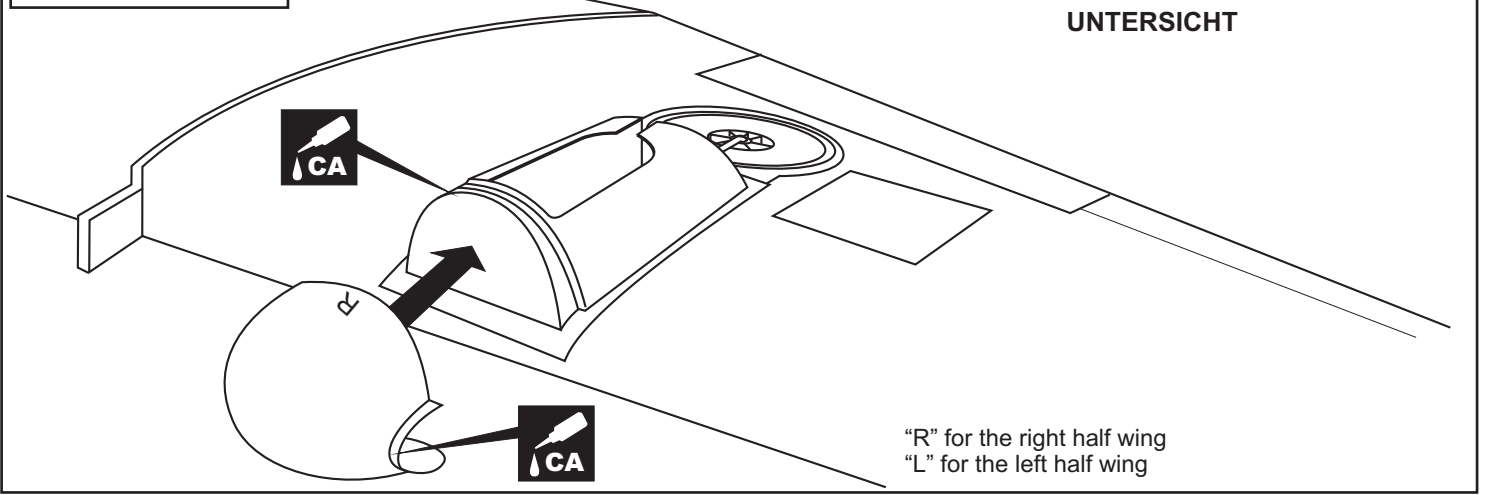

"R" for the right half wing  
"L" for the left half wing

# 8- Flap, Aileron servo / Flap, querruder servo

WING - BOTTOM VIEW / UNTERSICHT

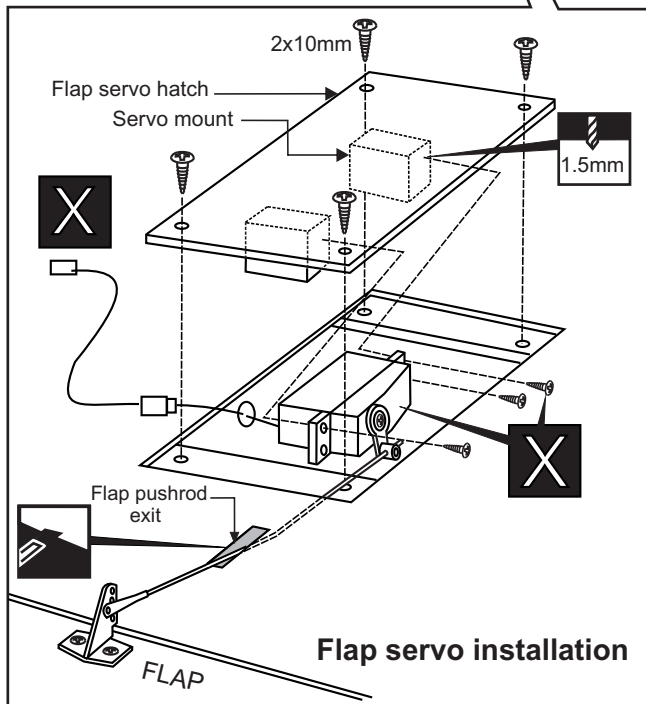
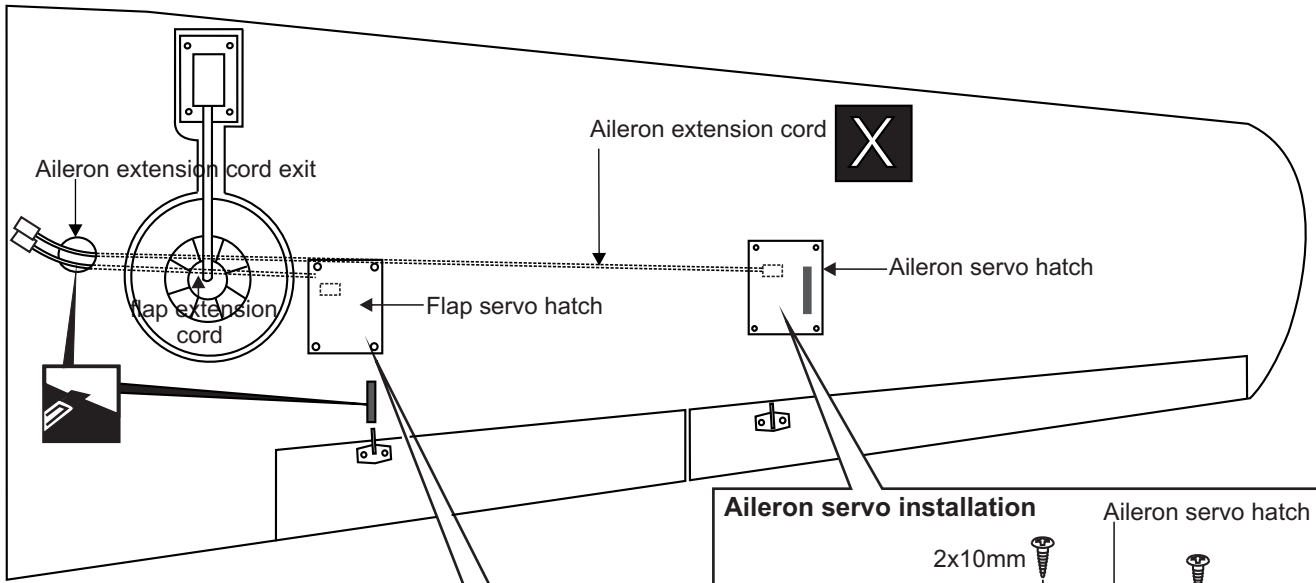

**Flap servo installation**

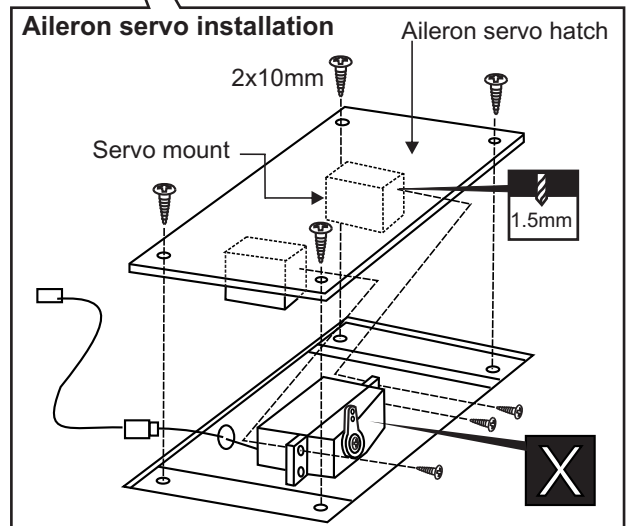

**Aileron servo installation**

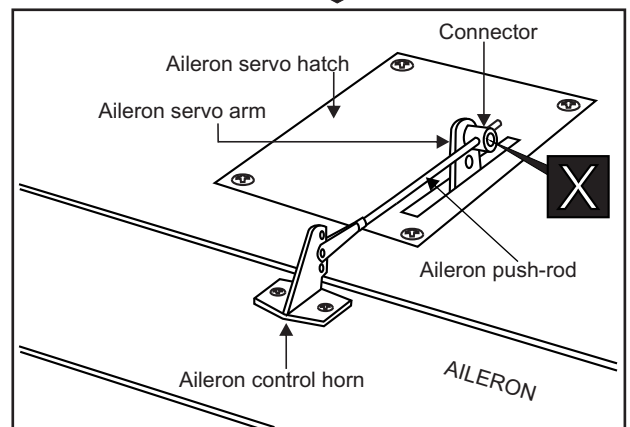

Connector 2mm  
 .....4

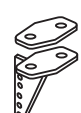
Plastic control horn  
 .....4 set

## 9- Horizontal stabilizer / Leiwerke

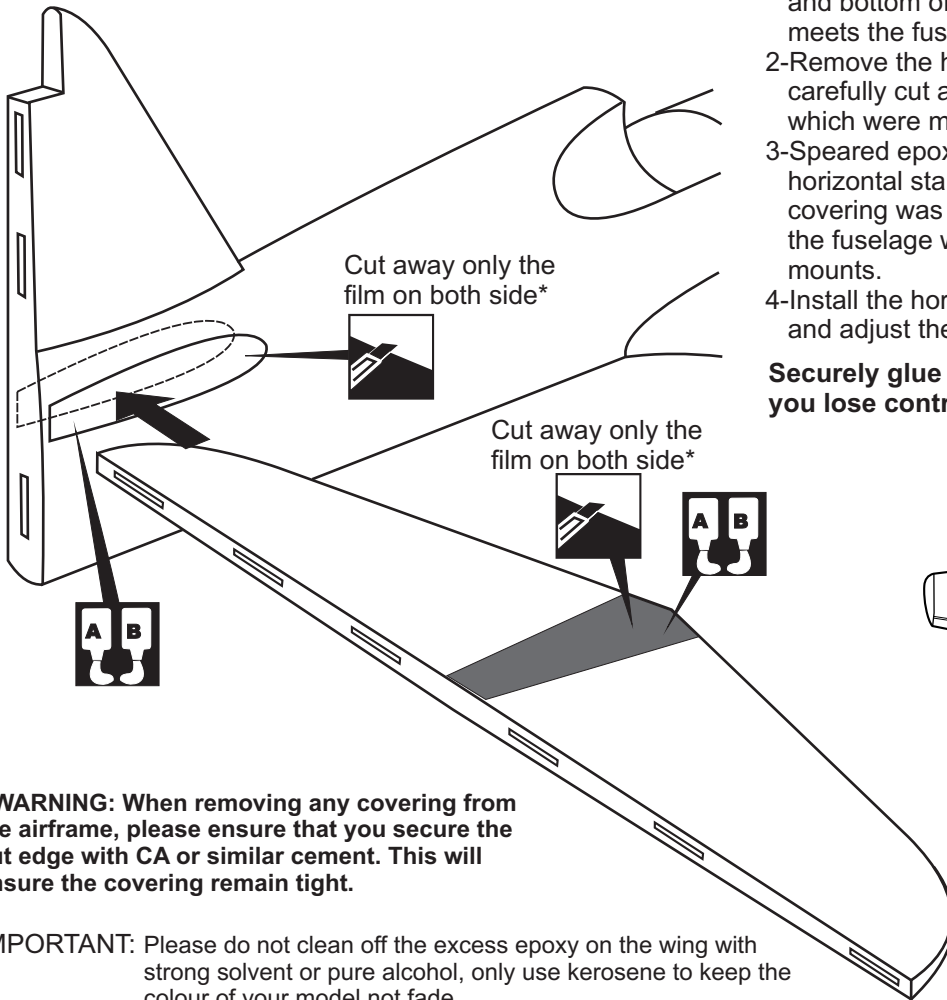

- 1-Trial fit the horizontal stabilizer into the fuselage. Use a pencil to carefully trace around the top and bottom of the horizontal stabilizer where it meets the fuselage.
  - 2-Remove the horizontal stabilizer from the fuselage, carefully cut away the covering inside the lines which were marked in steep 1.
  - 3-Spread epoxy onto the bottom and top of the horizontal stabilizer along the area where the covering was removed in the previous step and to the fuselage where the horizontal stabilizer mounts.
  - 4-Install the horizontal stabilizer into the fuselage and adjust the alignment as described in step 1.
- Securely glue together. If coming off during flight, you lose control of your air plane.**

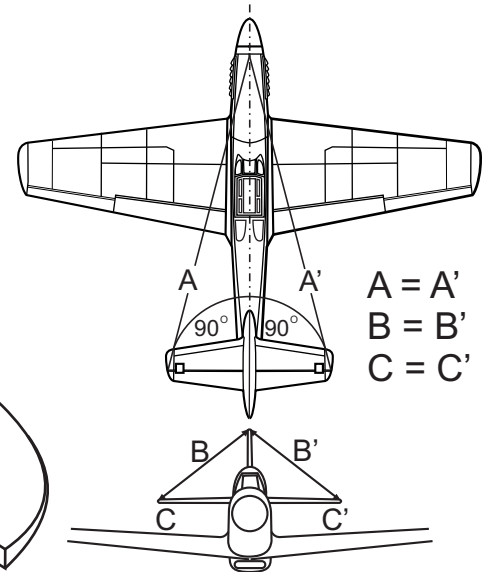

**\* WARNING:** When removing any covering from the airframe, please ensure that you secure the cut edge with CA or similar cement. This will ensure the covering remain tight.

**IMPORTANT:** Please do not clean off the excess epoxy on the wing with strong solvent or pure alcohol, only use kerosene to keep the colour of your model not fade.

## 10- Elevator installation / Höhenruder

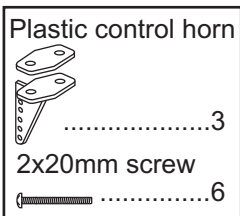

**Securely glue together. If coming off during flight, you lose control of your air plane.**

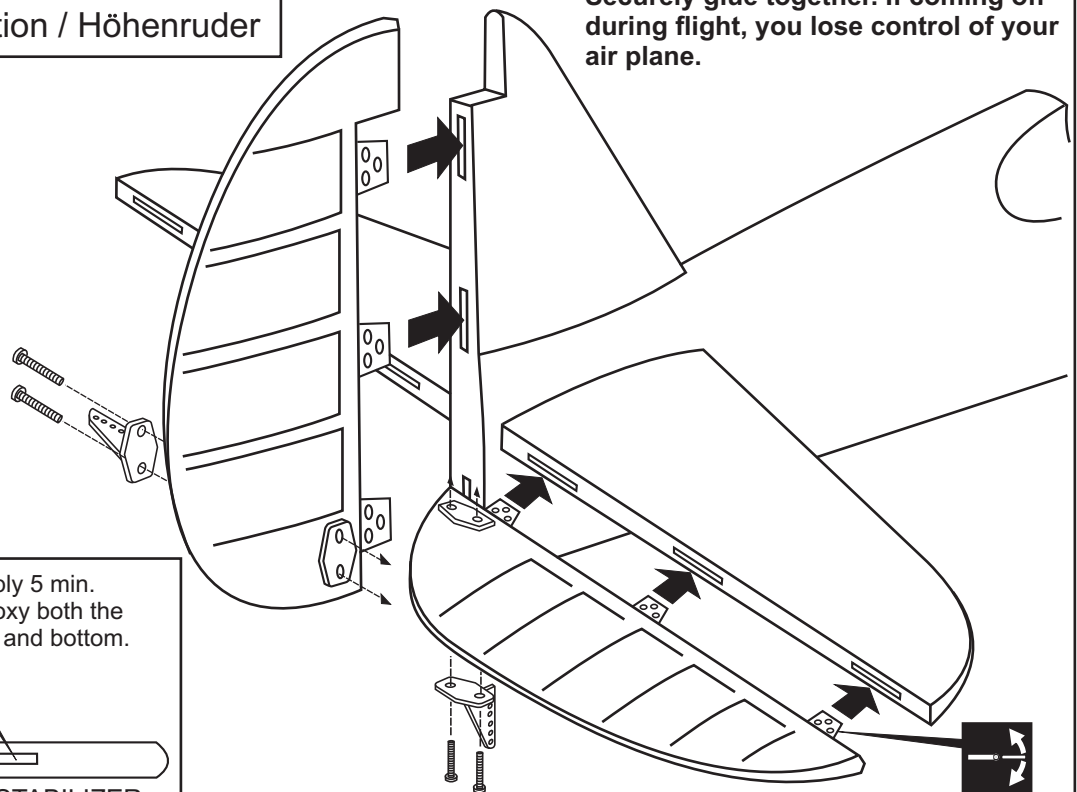
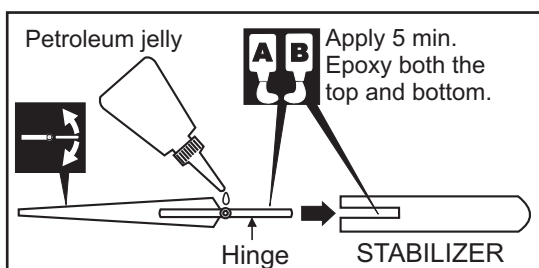

Apply a thin layer of machine oil or petroleum jelly to only the pivot point of the hinges on the elevator, then push the elevator and its hinges into the hinge slots in the trailing edge of the horizontal stabilizer. There should be a minimal hinge gap.

When satisfied with the and alignment, hinge the elevator to the horizontal stabilizer using 5 minute epoxy. Make sure to apply a thin layer of epoxy to the top and bottom of both hinges and to inside the hinge slots. Repeat the previous procedures to hinge the second elevator to the other side of the horizontal stabilizer.

# 11- Tail gear / Heckspornrad

## FUSELAGE - BOTTOM VIEW UNTERSICHT

5/64"(2mm) collar

1/8x15/32"  
(3x12mm) screw

.....2

Tail gear horn

.....1

5/64"(2mm) collar

.....1

1-Place the tail gear mount on the bottom of the fuselage as show, mark the mounting hole positions with a pencil.  
2-Remove the tail gear mount from the fuselage, Drill the two mounting holes as marked.

3-Cut a 5/64"(2mm) wide slot which is 5/16"(8mm) length and 5/16"(8mm) depth on the bottom of the rudder as shown.

4-Trial fit the tail gear horn into the slot. Do not glue at this time.  
5-Slide the tail gear into the tail gear horn. Secure the tail gear mount in place using the two 3x12mm screw.  
6-Secure the tail gear horn in place using CA glue as shown.

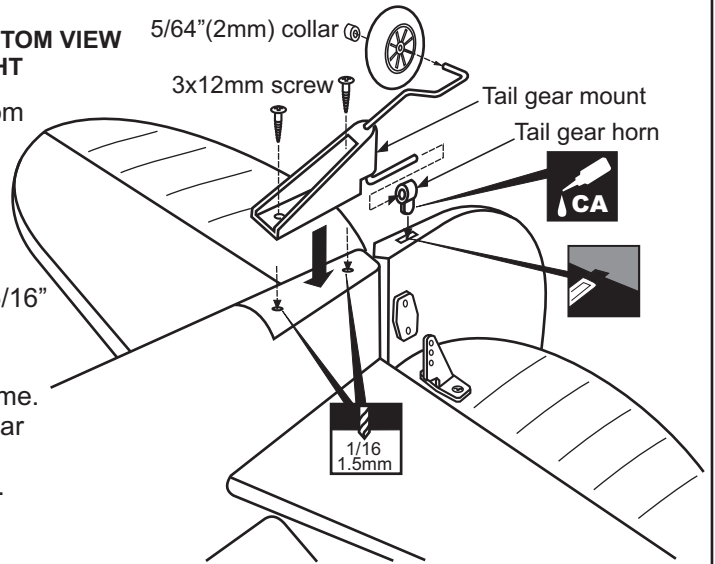

# 12- Engine 4T / Viertarkmotoren

Engine thrust on balk head is already adjust at factory

Ply engine mount plate

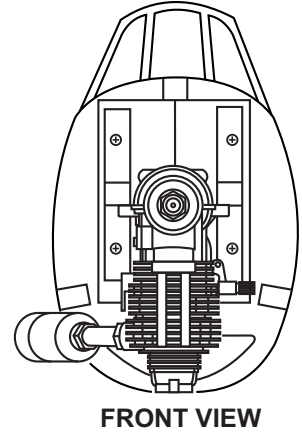
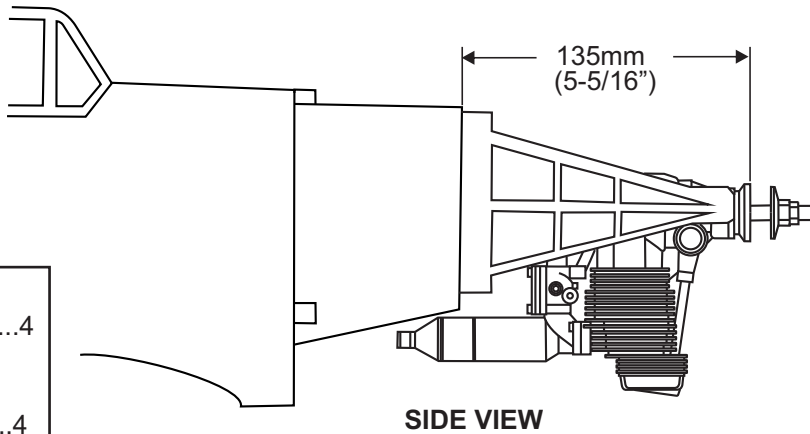
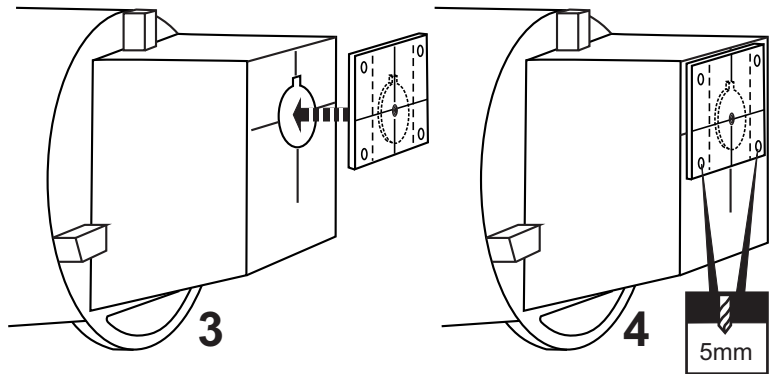
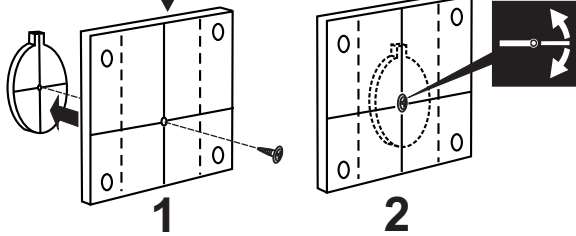

4x25mm screw

.....4

Blind-nut

.....4

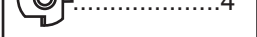

# 13- Engine 2T / Zweitarkmotoren

## FRONT VIEW

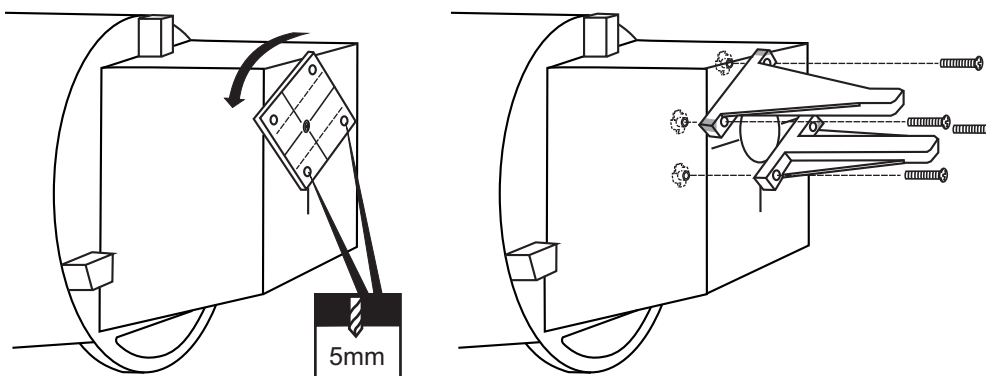

## 14- Brushless motor

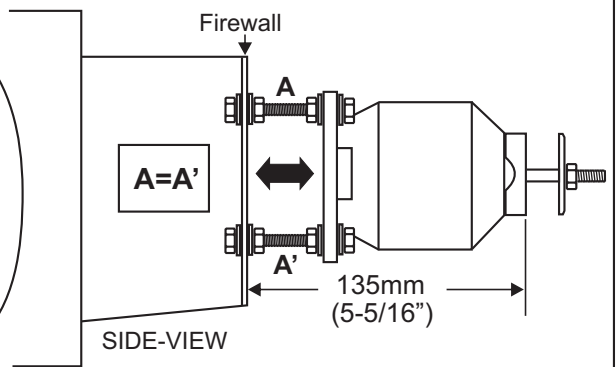
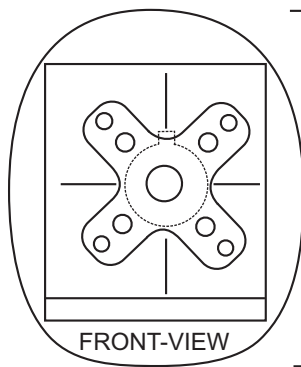
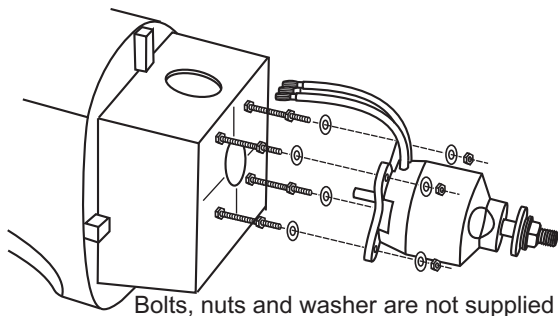

## 15- Fuel tank / Treibstofftank

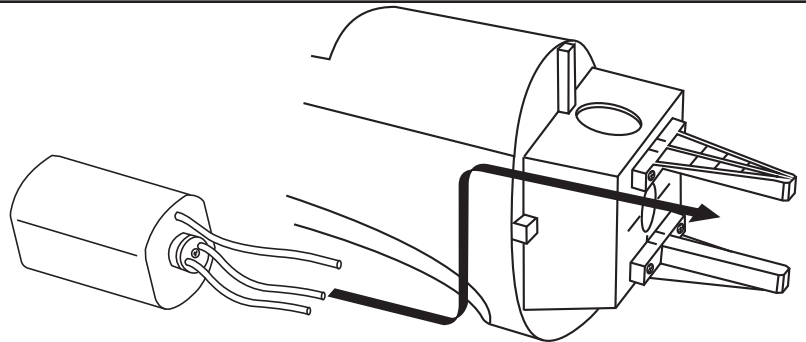
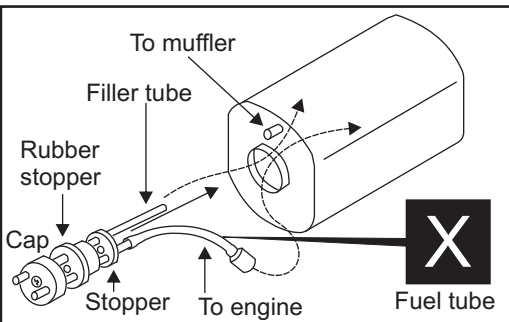

After confirming the direction, insert this assembly, clunk end first, into the fuel tank and tighten and screw the fuel tank cap on firmly.

## 16- Cowling / Motorhaube

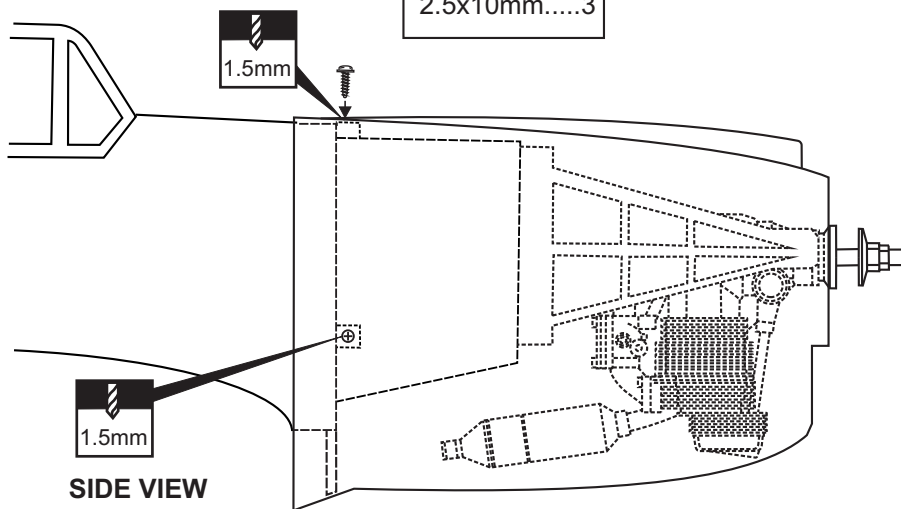

## 17- Servo

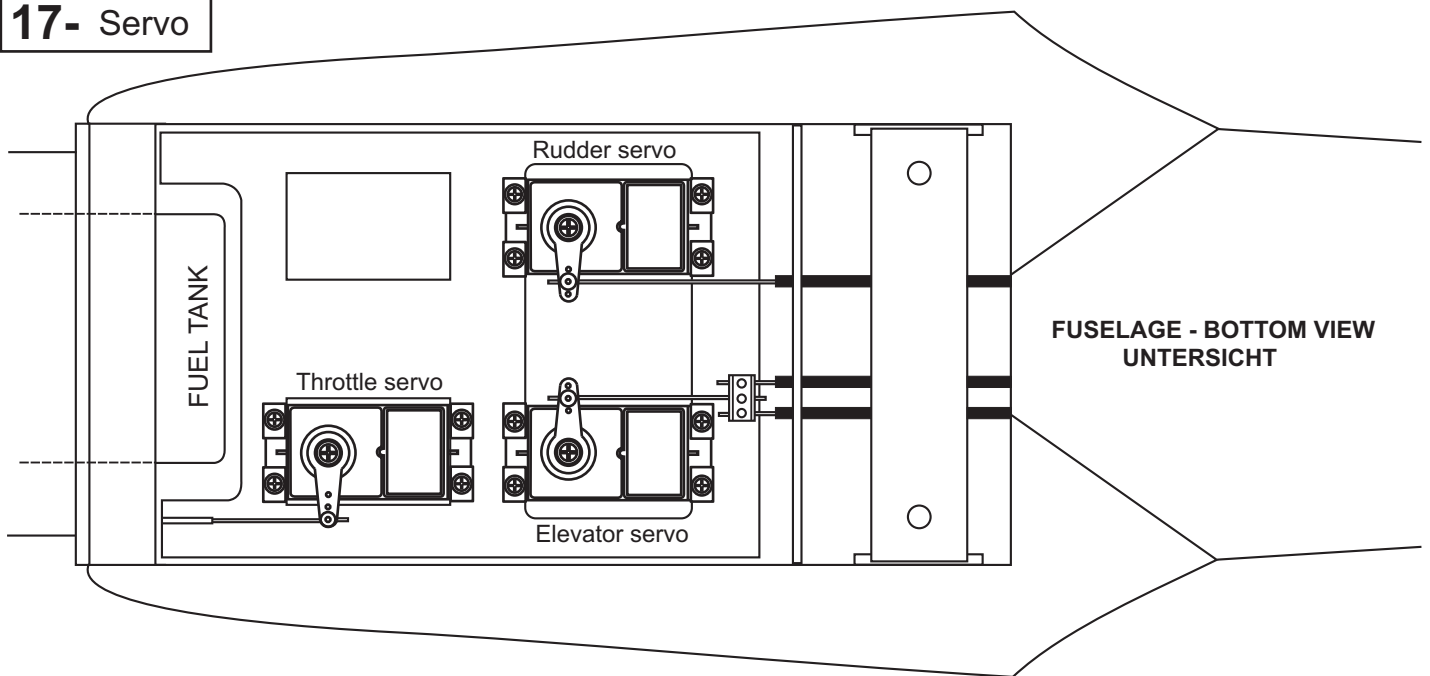



# 18- Linkages / Anlenkungen

Connector

 ..... 3

Connector

 ..... 1

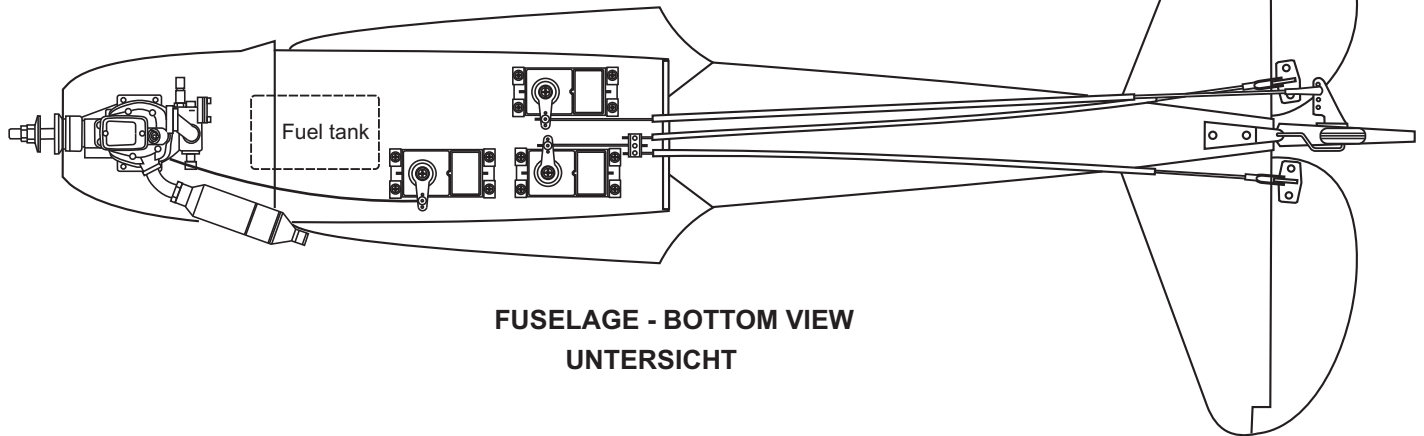
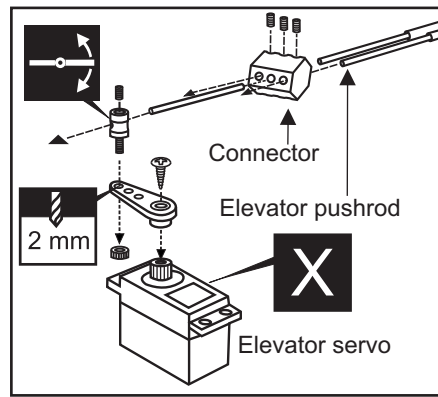
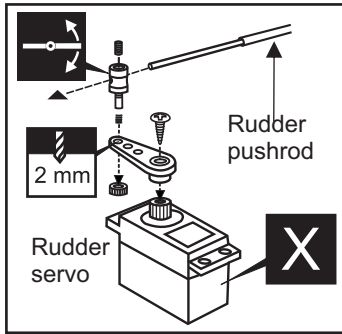

# 19- ABS Shield

FUSELAGE - BOTTOM VIEW  
UNTERSICHT

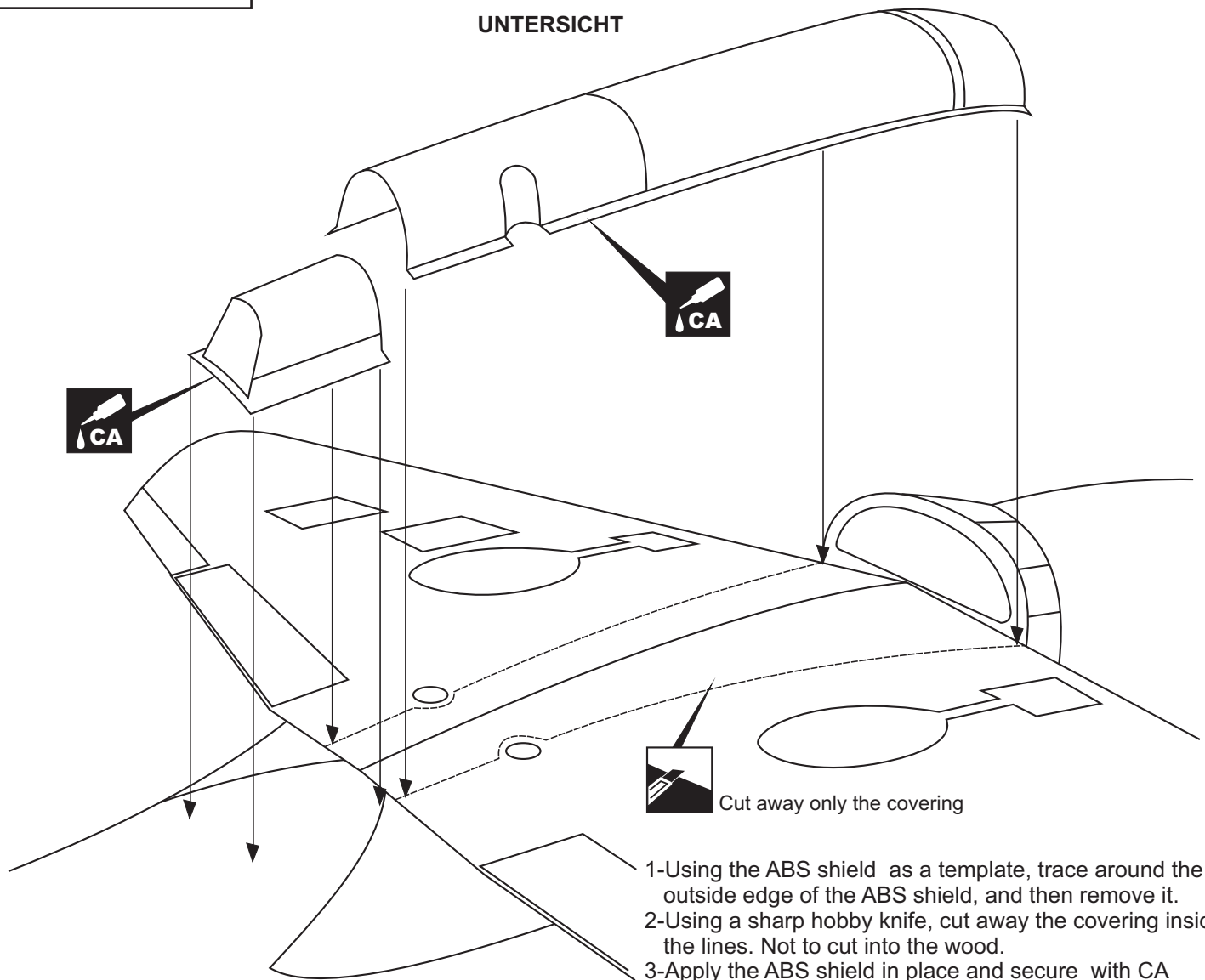

## 20- Canopy / Kabinenhaube

2x10mm screw  
 .....4

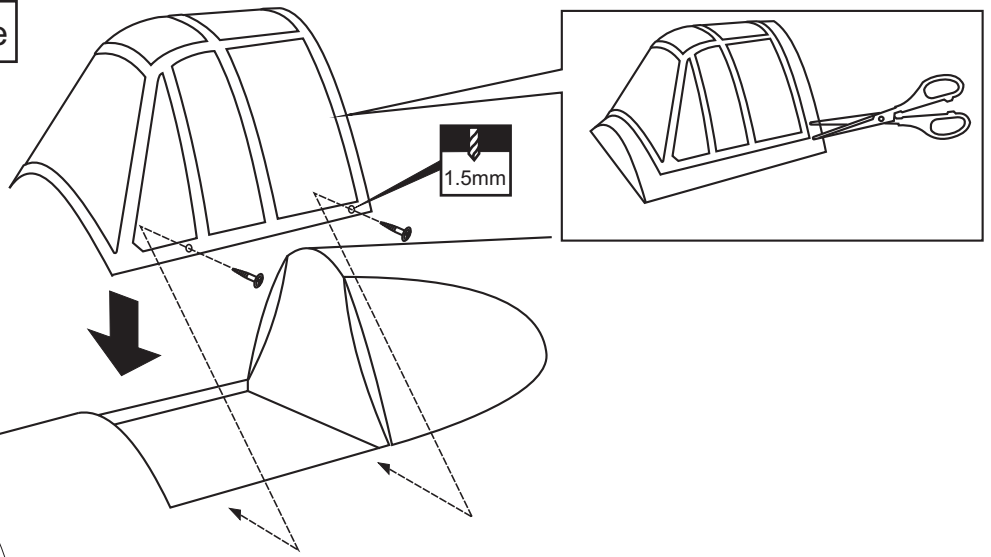

## 21- Decor / Aufkleber

CHINESE AIR-FORCE

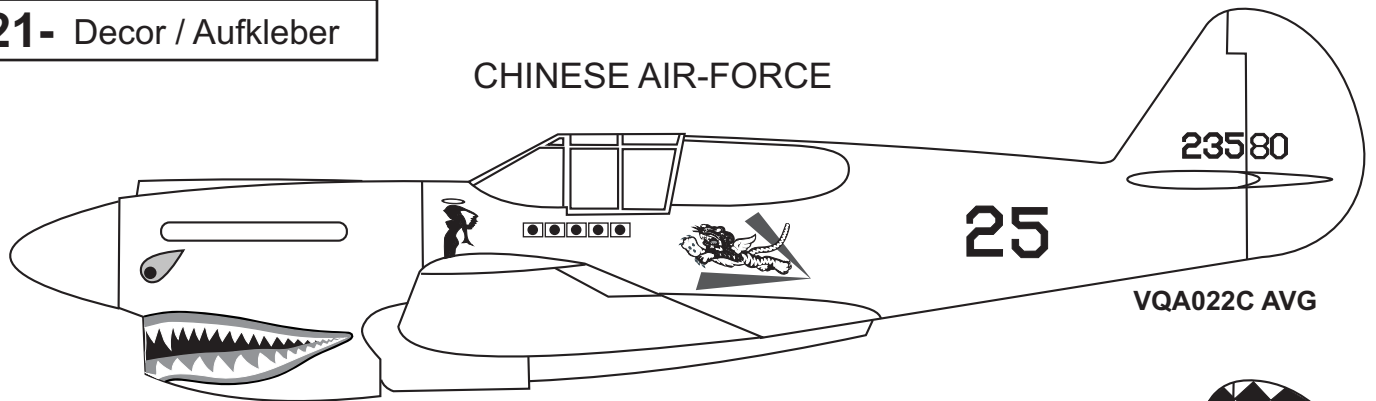

CHECKER TAIL VERSION

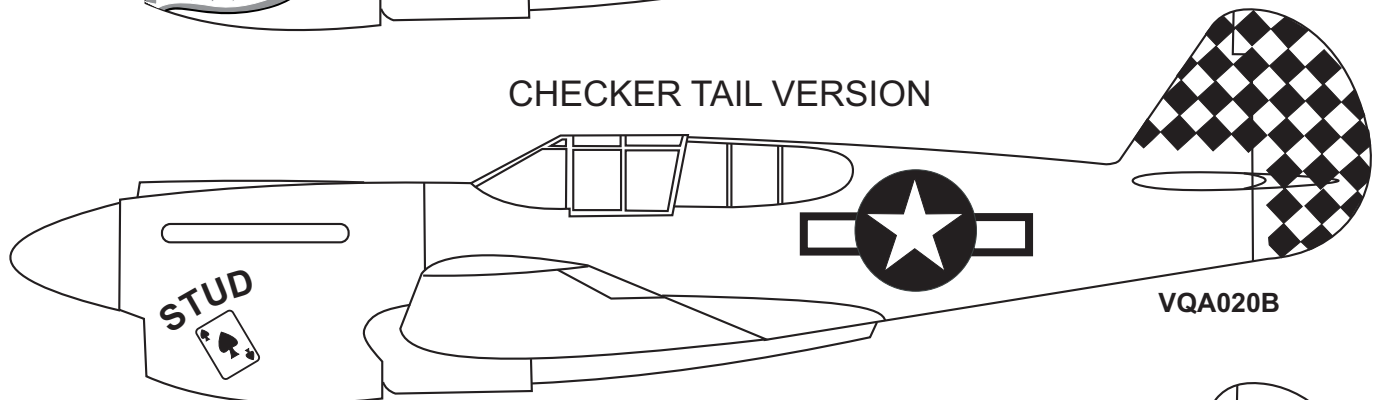

US.ARMY

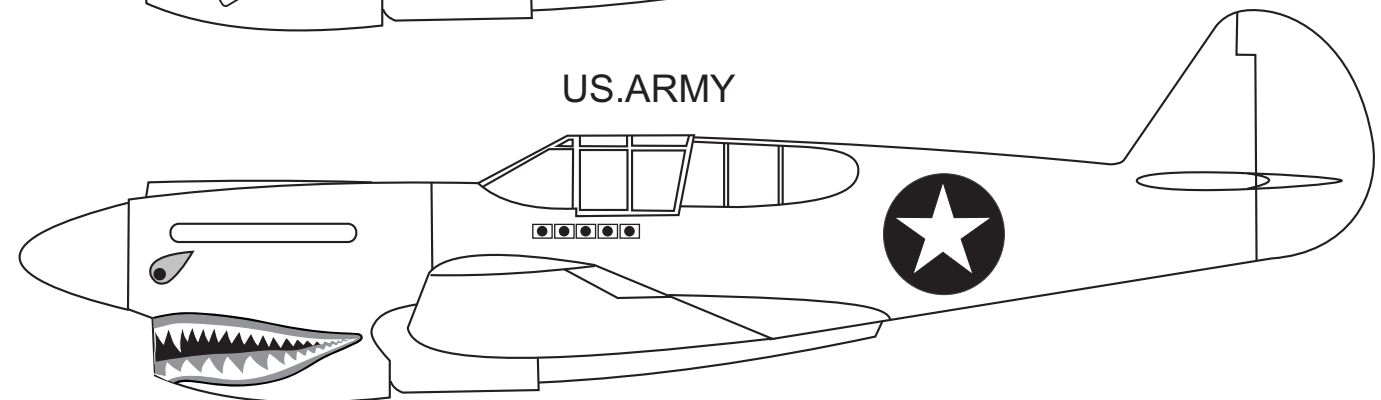

Note: Cut out the stickers and apply them in the proper area. Do not peel the backing paper off all at once. Peel off one corner of the backing and cut off with scissors. Arrange sticker on model and when satisfied adhere the corner without backing. Carefully peel back the rest of the backing while at the same time adhering the rest of the sticker. Try not to make air bubbles, if there are some, carefully puncture sticker (center of bubble) but not model surface with the tip of the knife or sharp pin and squeeze out the air. At curves stretch sticker and apply a little heat so that no ceases occur. Cut off the excess that is produced.

## 22- Balance / Schwerpunkt

**DO NOT try to fly an out-of-balance model !**

Note: If necessary, move the battery pack or add weight to either the tail or nose until the correct balance is achieved.

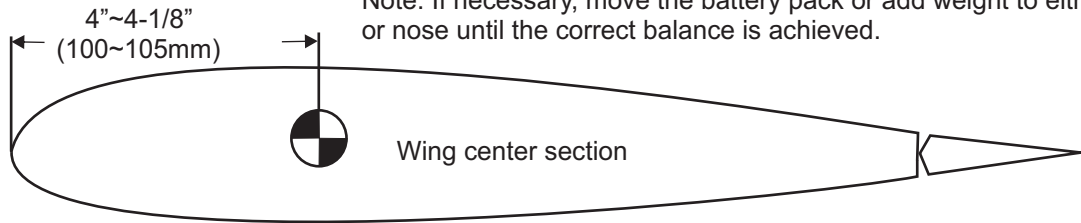

## 23- Control surface / Ruderausschlage

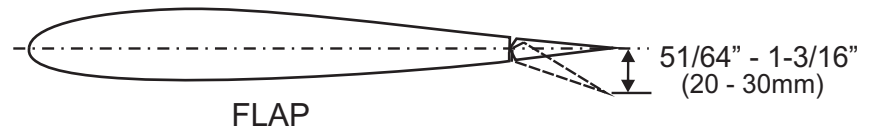
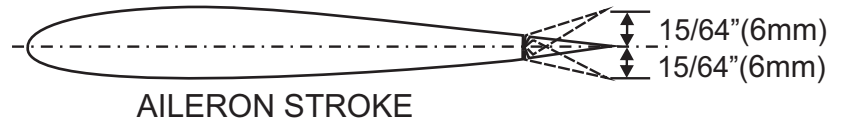
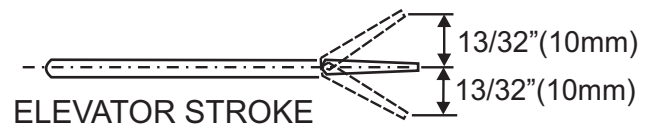
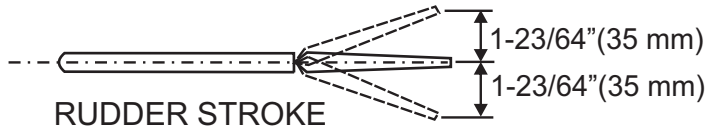

Adjust the travel of the control surfaces to achieve the values stated in the diagrams.  
These value will be suitable for average flight requirements. Adjust the values to suit your particular needs.

**IMPORTANT:** Please do not clean your model with pure alcohol or strong solvent, only use liquid soap with water or use glass cleaner to clean on surface of your model to keep the colour not fade.

All details are subject to change  
without notice !

**Technische Änderungen und Irrtümer  
vorbehalten !**