

RADIO CONTROL MODEL

Semi Scale – Almost ready to fly

NORTH AMERICAN

P-51D MUSTANG

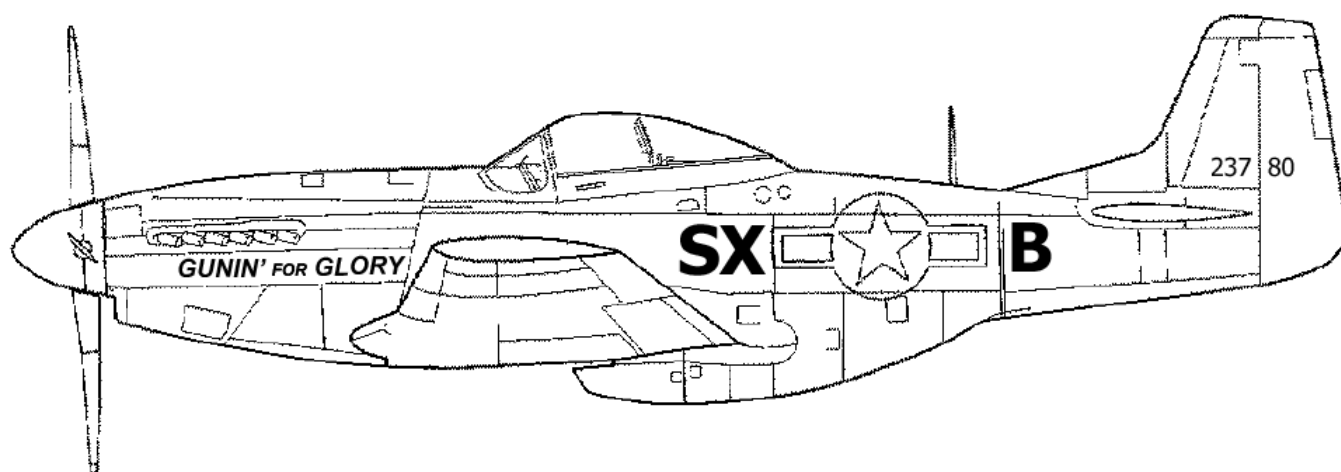

ASSEMBLY INSTRUCTION

.40 - .46 CLASS – 2 CYCLE ENGINE

.60 - .70 CLASS – 4 CYCLE ENGINE

WARNING: This radio control model is not a toy. If modify or flown carelessly, it could go out of control and cause serious bodily injury or property damage, It is your responsibility to build this kit correctly, to properly install all components and to seek the help of an experienced R/C pilot for a pre-flight safety inspection and flight test.



REQUIRED FOR OPERATION (Purchase separately)

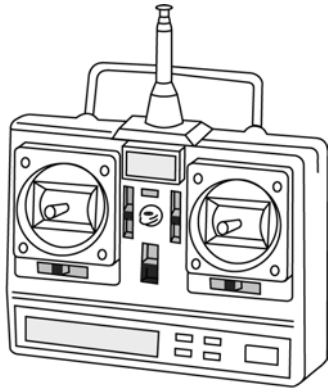

Minimum of 4 channel airplane radio (with 4 standard servos). A 5 channel radio is req. for retracts. (5 standard servo)



For 40 ~ 46 (2 cycle engine)
10.5x6 ~ 11x6

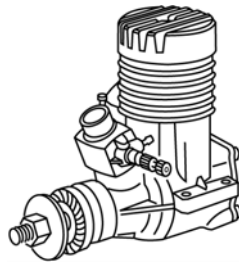

40 ~ 46 2 cycle
60 ~ 70 4 cycle

For 60 ~ 70 (4 cycle engine)
12x6 ~ 13x7

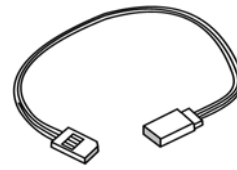

Extension for aileron servo

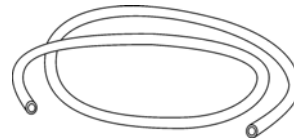

Silicon tube

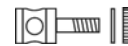

Linkage Stopper

GLUE (Purchase separately)



Cyanoacrylate Glue



Silicon Glue



Epoxy Glue (30 minutes type)

TOLLS REQUIRED (Purchase separately)

Hobby knife 

Needle nose Pliers 

Sander 

Phillip screw driver 

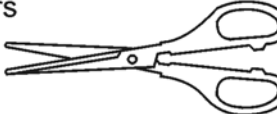
Scissors 

Hex Wrench 

Awl 

Wire Cutters 

The pre-covered film on ARF kit may wrinkle due to variations of temperature. Smooth out as explained right.

* Use an iron or head gun. Start as low setting. Increase the setting if necessary. If it is too high, you may damage the film

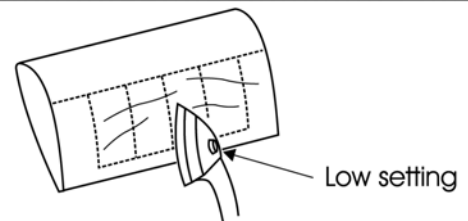

Drill holes with the specified diameter (here: 1.5mm).



Pay close attention here.



Cut of shaded portion



Ensure smooth non-binding movement while assembling



Apply epoxy glue



Apply instant glue (CA glue, super glue).



Assemble left and right sides the same way.



Must be purchased separately.

4- Retract Push rod

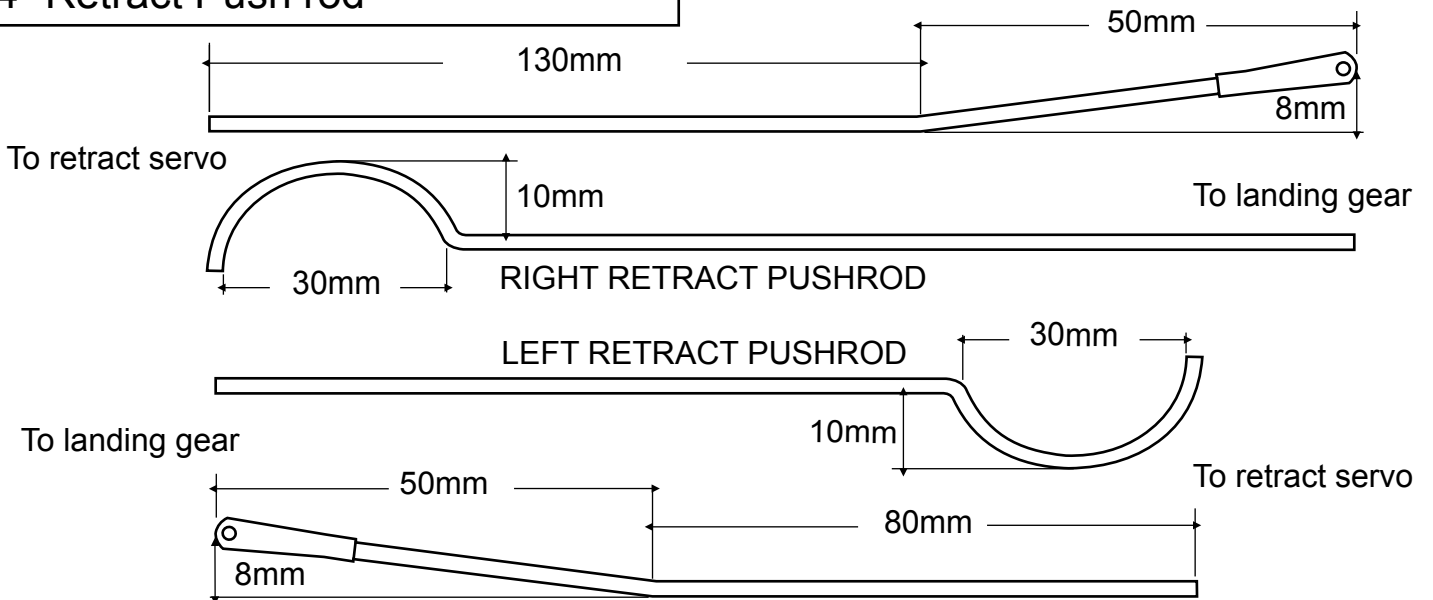

5- Retract landing gear Installation

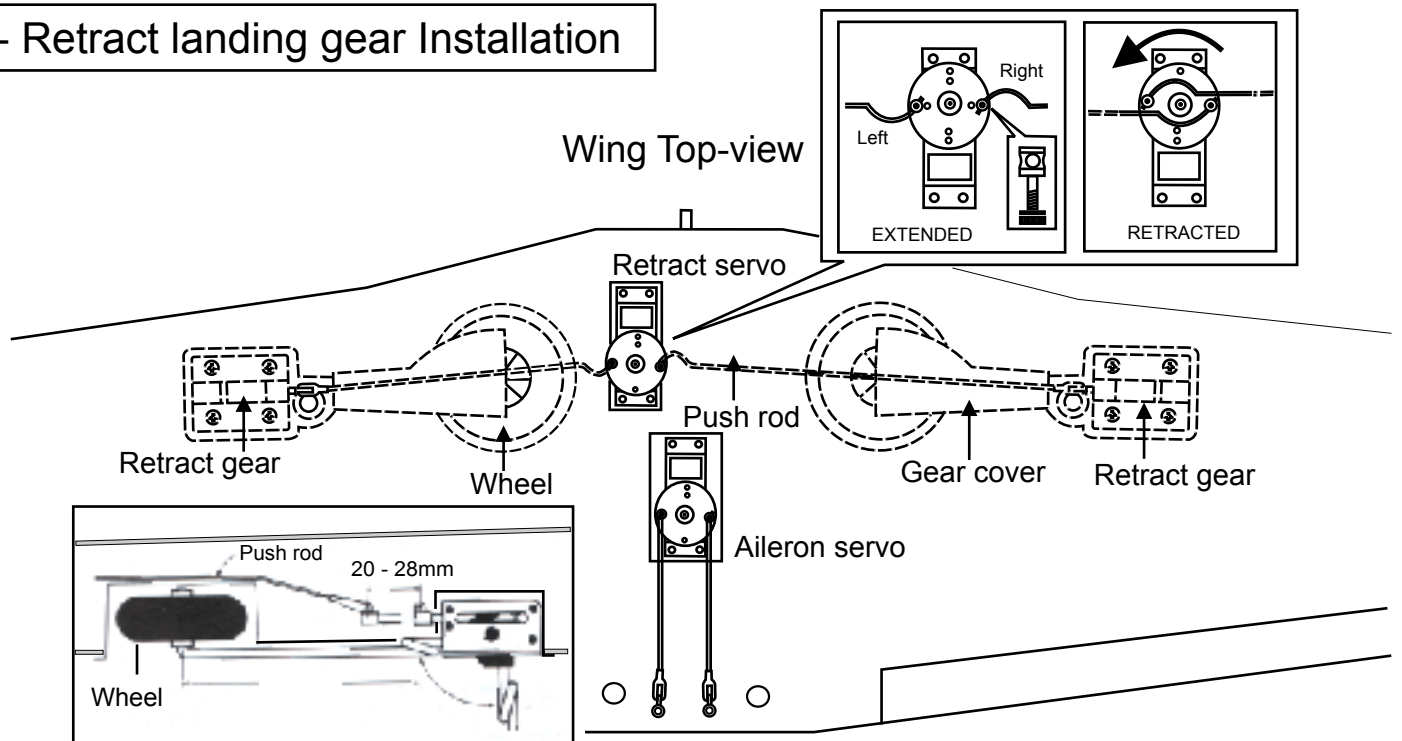

6- Fix Gear

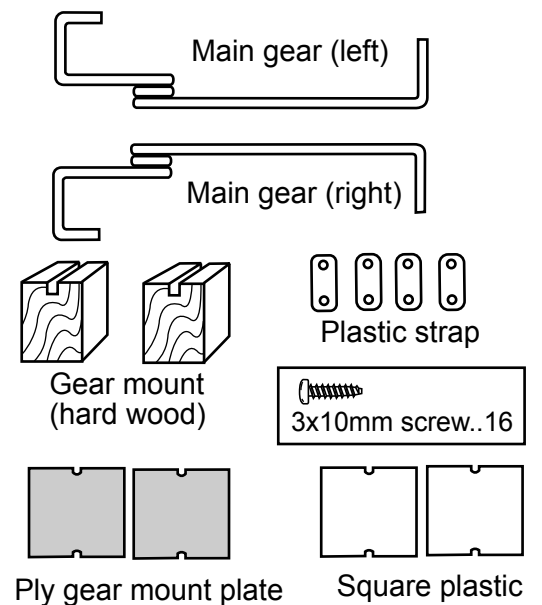
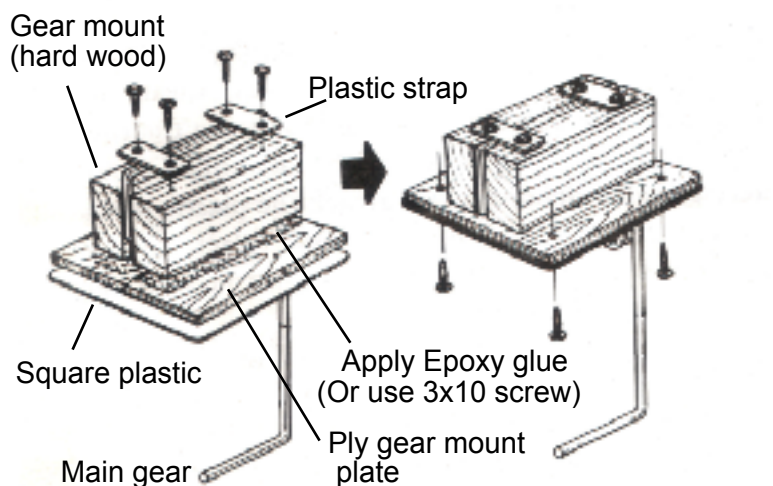

7- Gear cover

L/R

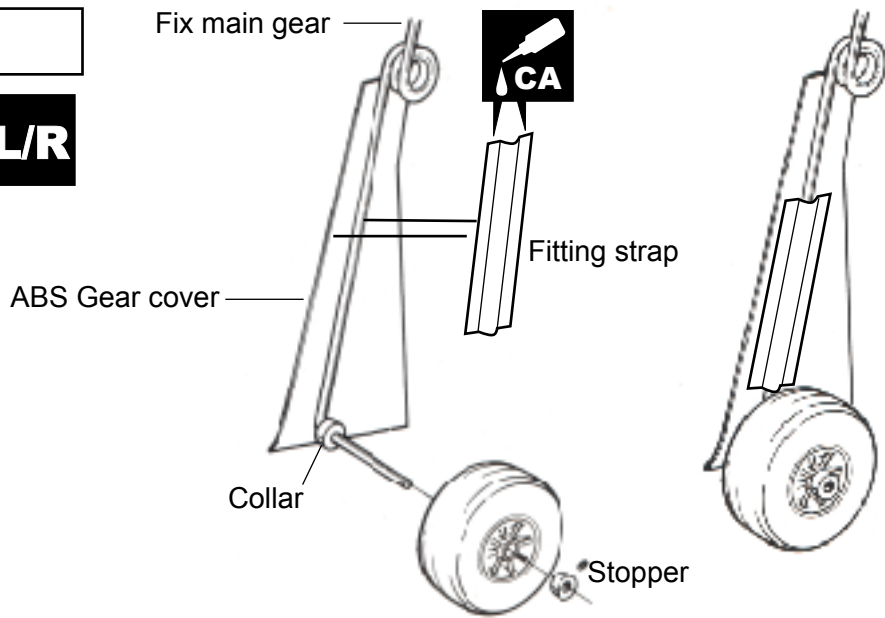

8- Fix gear

Wing Bottom-view

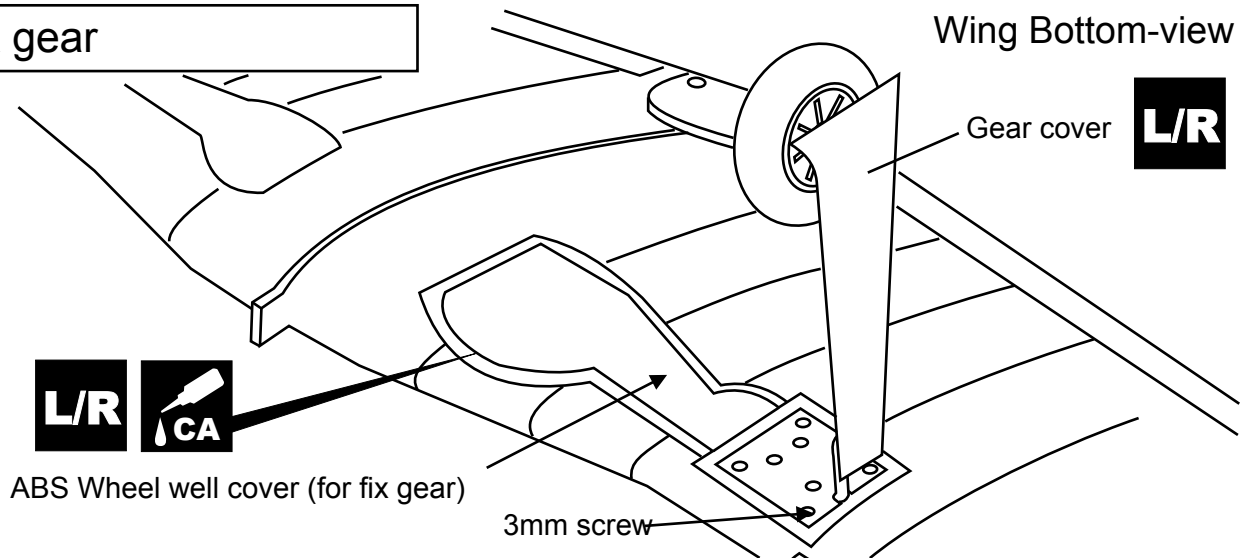

9- Air Scoop

Bottom-view

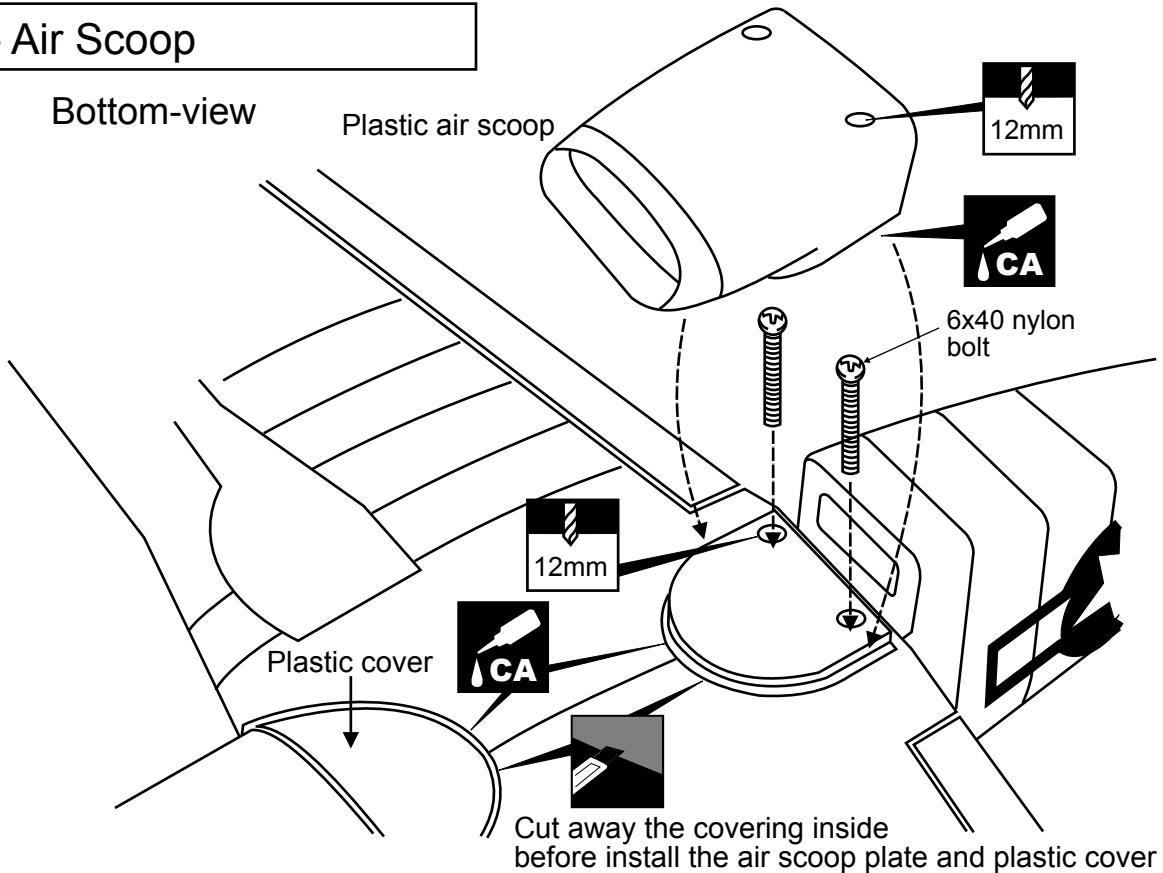

10- Air-scoop - Bottom wing cover

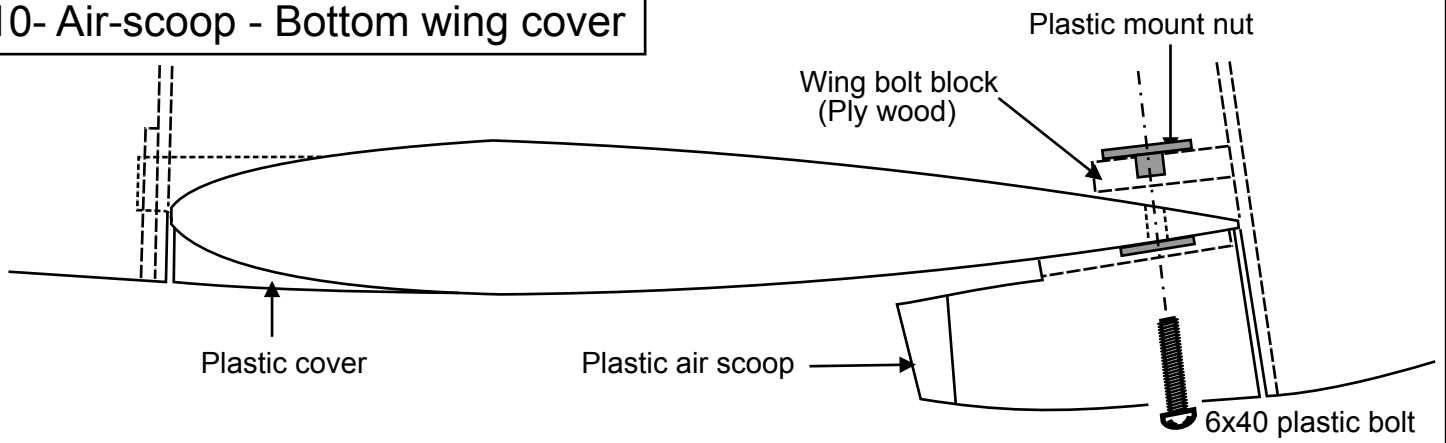

11- Four-stroke Engine

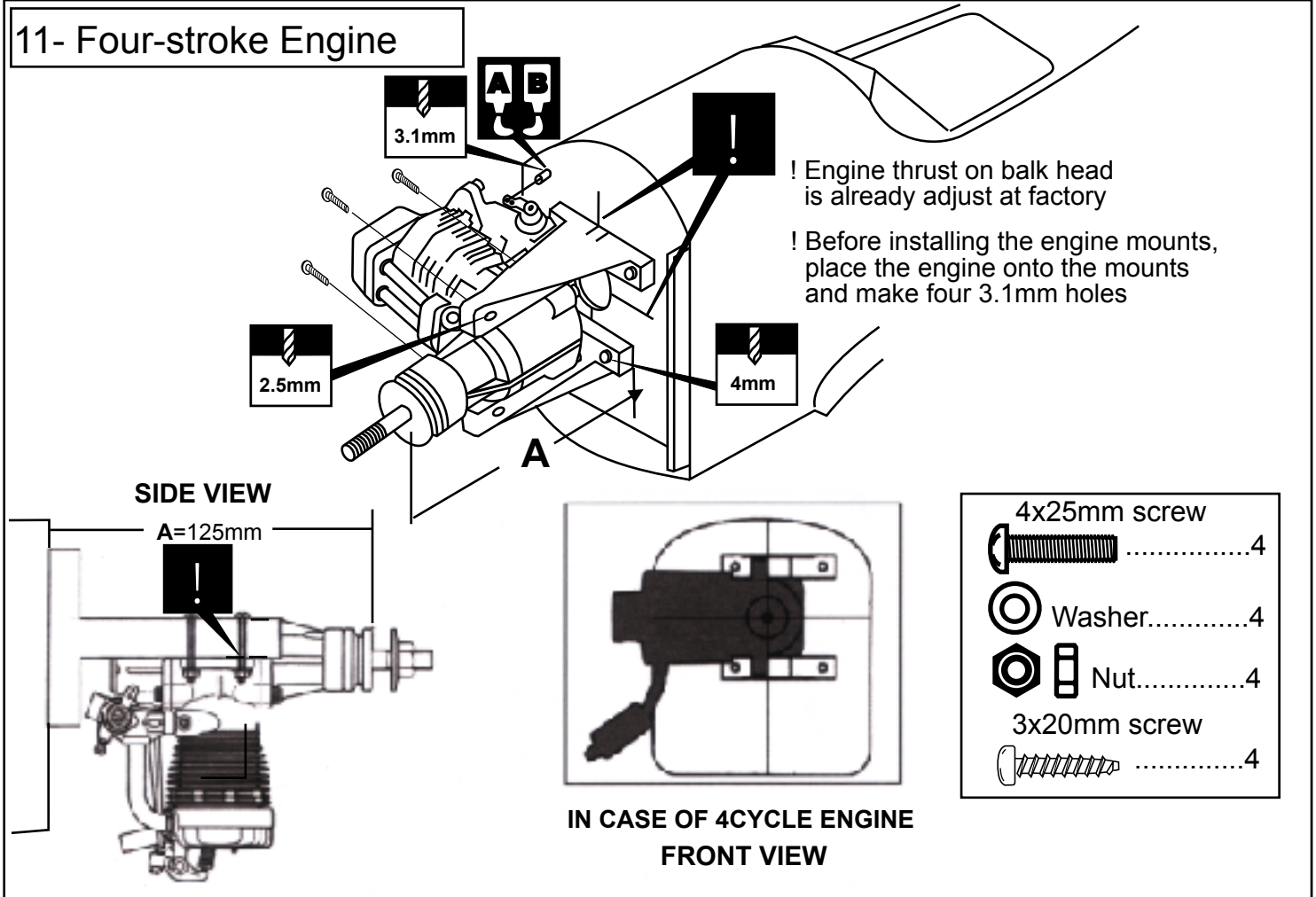

12- Two-stroke engine

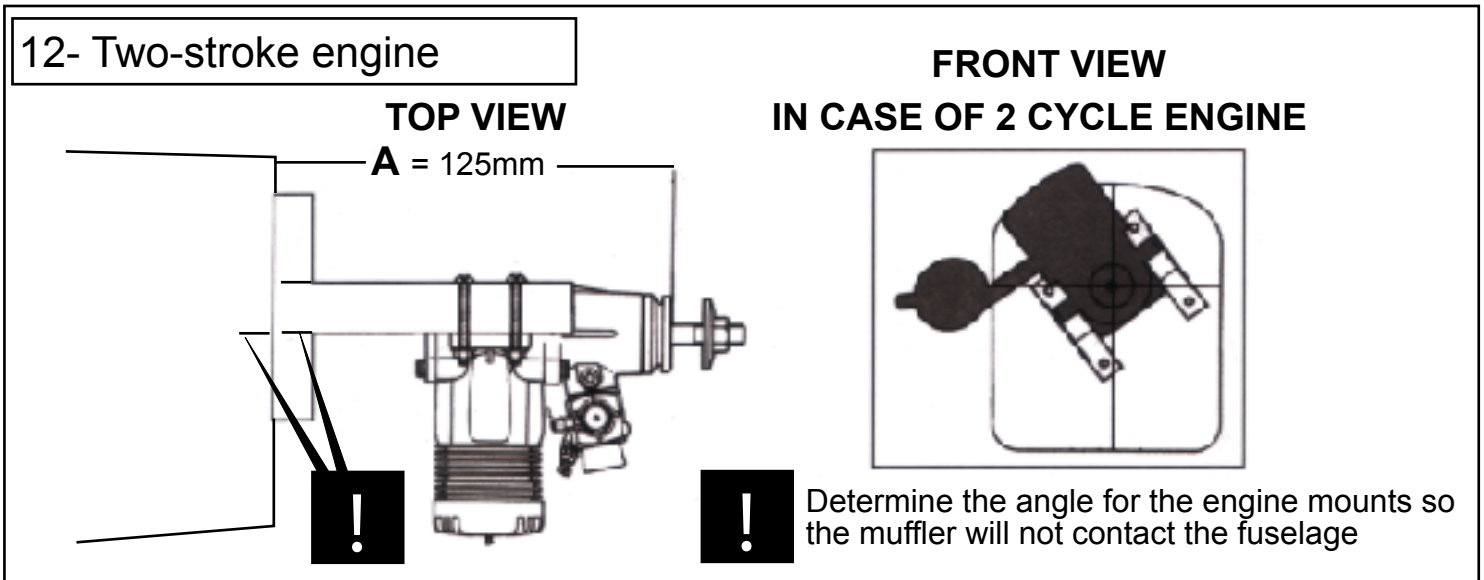

13- Fuel tank installation

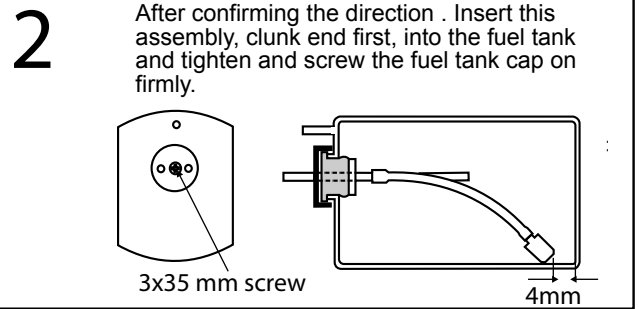
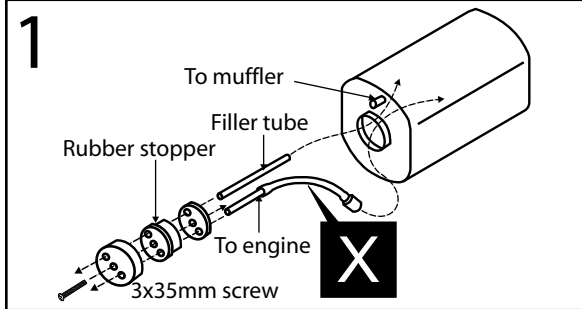
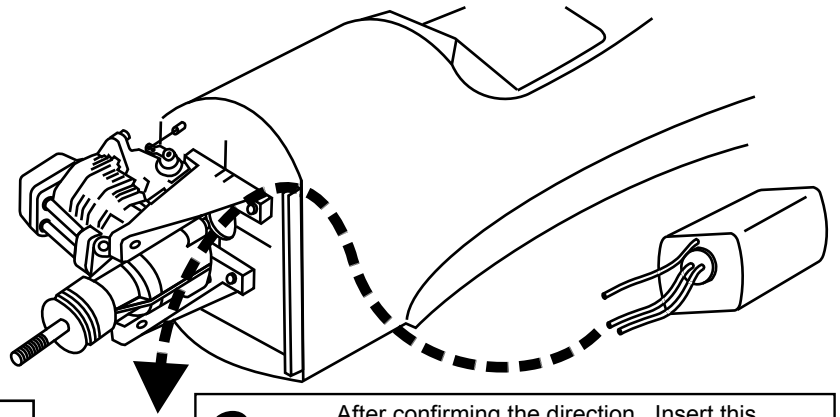

14- Vertical / Horizontal Tail

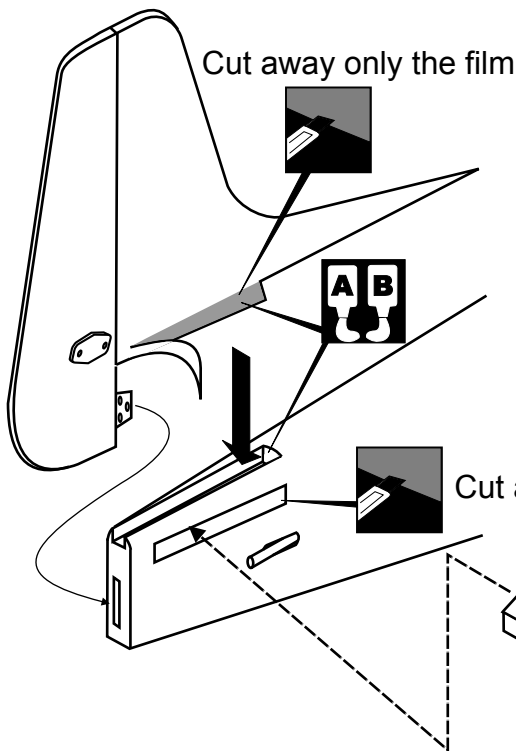

A = A'
B = B'

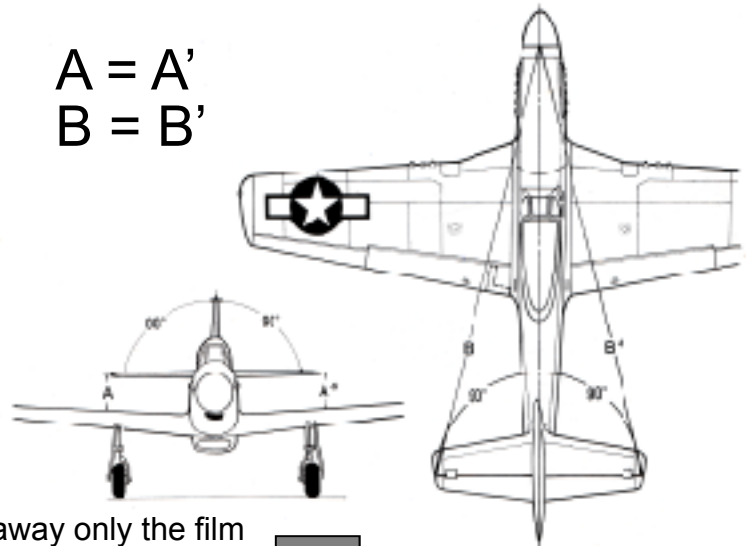

- Trial fit each part before gluing . Be certain that there are no gaps. If the parts will join, but with a gaps, sand or trim the parts a little at a time until the parts meet exactly with no gaps.
- When joining the stabilizer it is extremely important to use plenty of epoxy (30 minutes) or CA glue (thin type)
- Carefully slide the stabilizer into the fuselage, ensuring that they are accurately aligned, Using rubbing alcohol and paper towel, clean off the excess epoxy.

! Securely glue together. If coming off during flight, you lose control of your air plane.

15- Tail gear

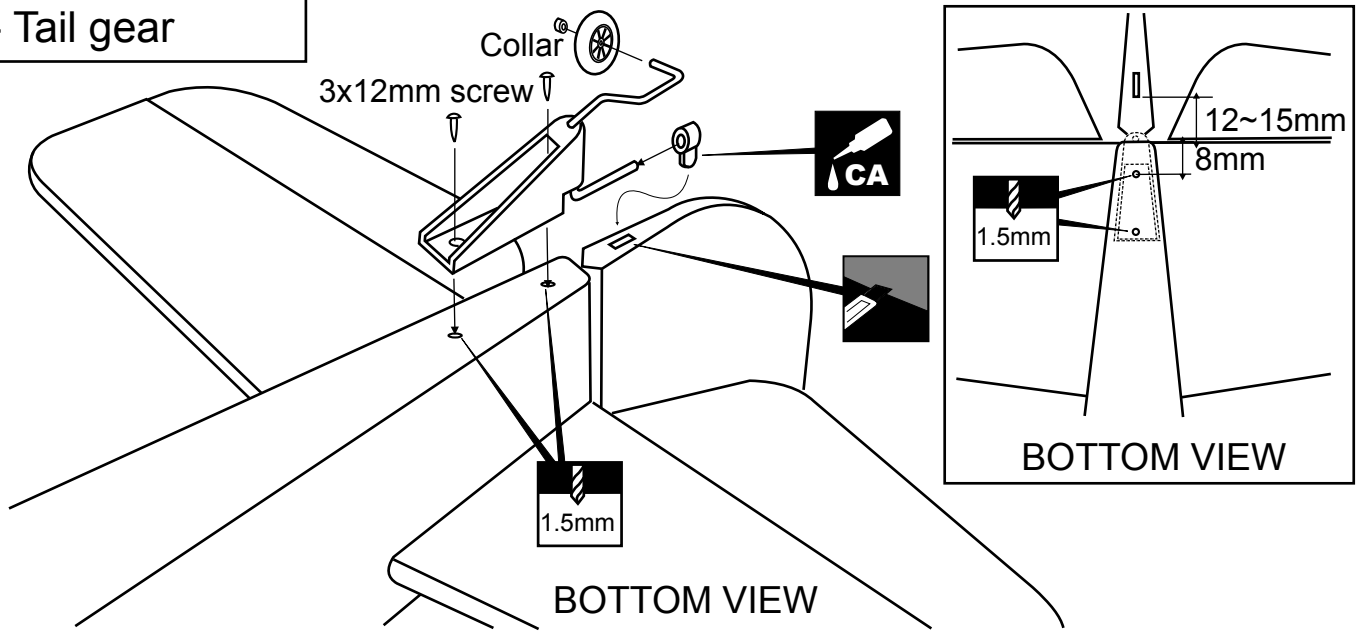

16- Linkages

Plastic control horn



.....1

Plastic back plate



.....1

2x10mm screw



.....2

-When you are satisfied with the alignment of the control horn mark the mounting hole positions with a felt tipped pen or a pencil.

-Remove the control horn and drill two 2mm (5/64") holes through the rudder and elevator.

-Attach the rudder control horn and elevator control horn using 2x10mm screws and a back plates.

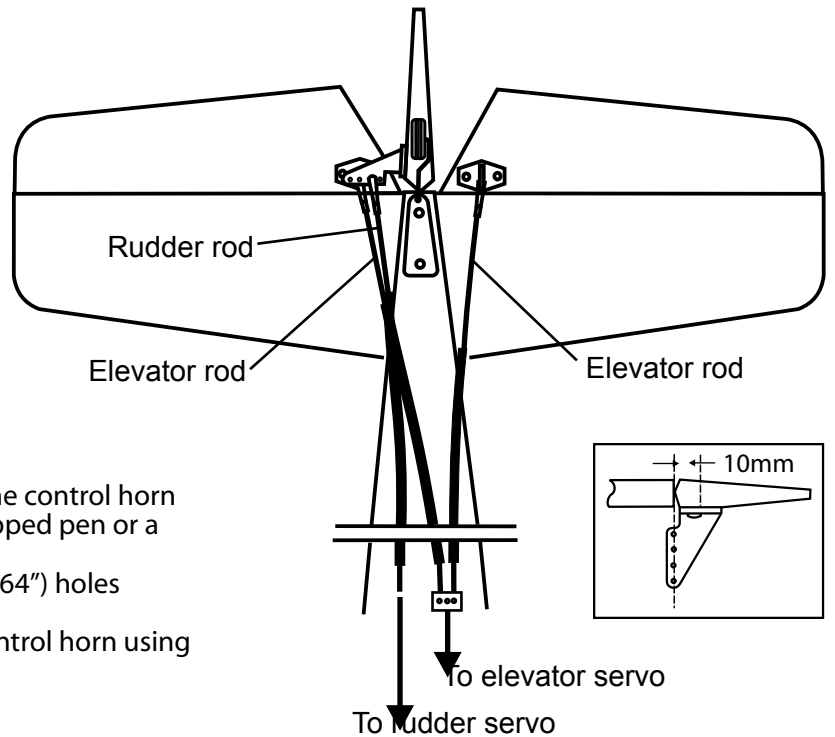

17- Radio Installation

Battery area (under tank, for 2T engine)

Battery area (for 4T engine)

Switch position (for 2T engine)

Receiver area

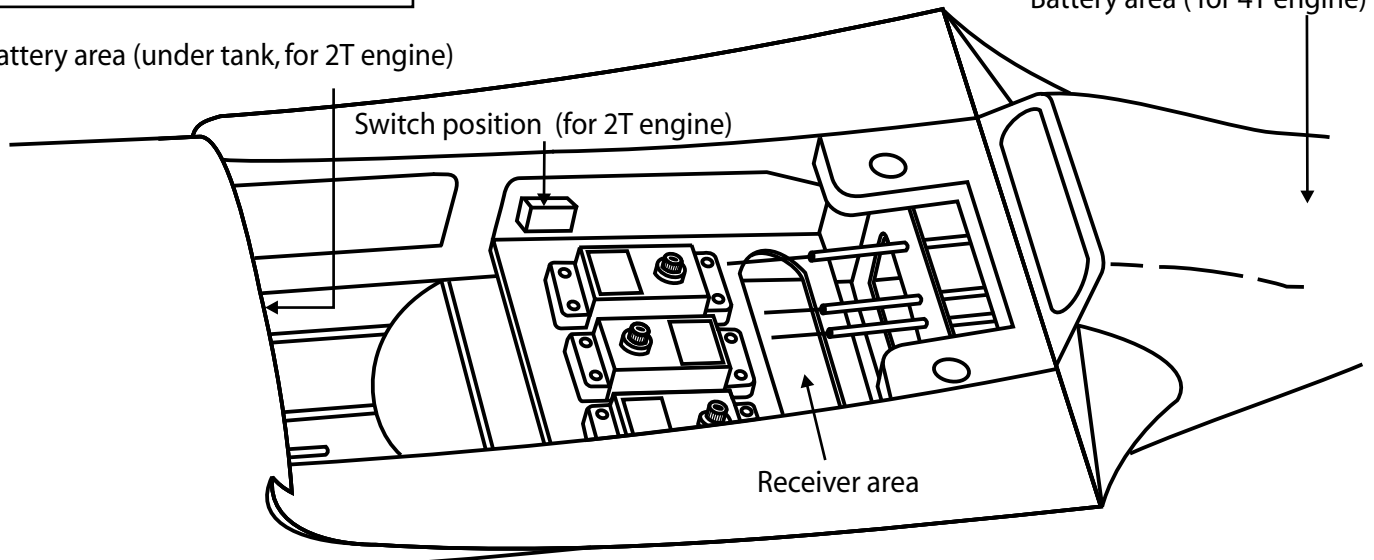

18-Servo / Push rod

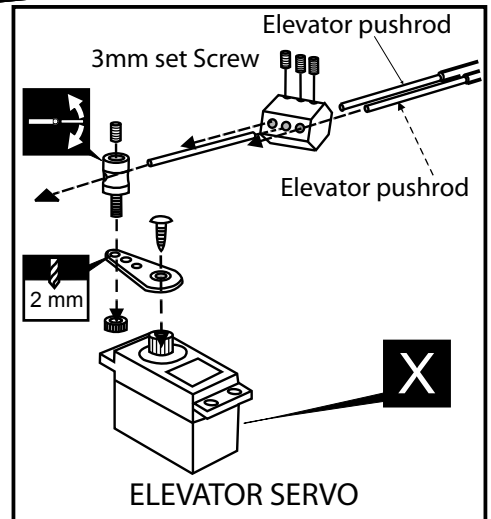
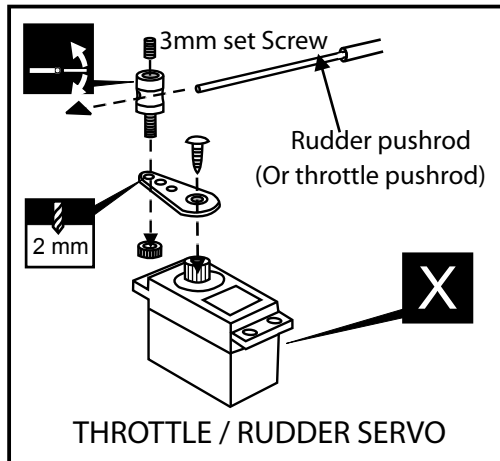
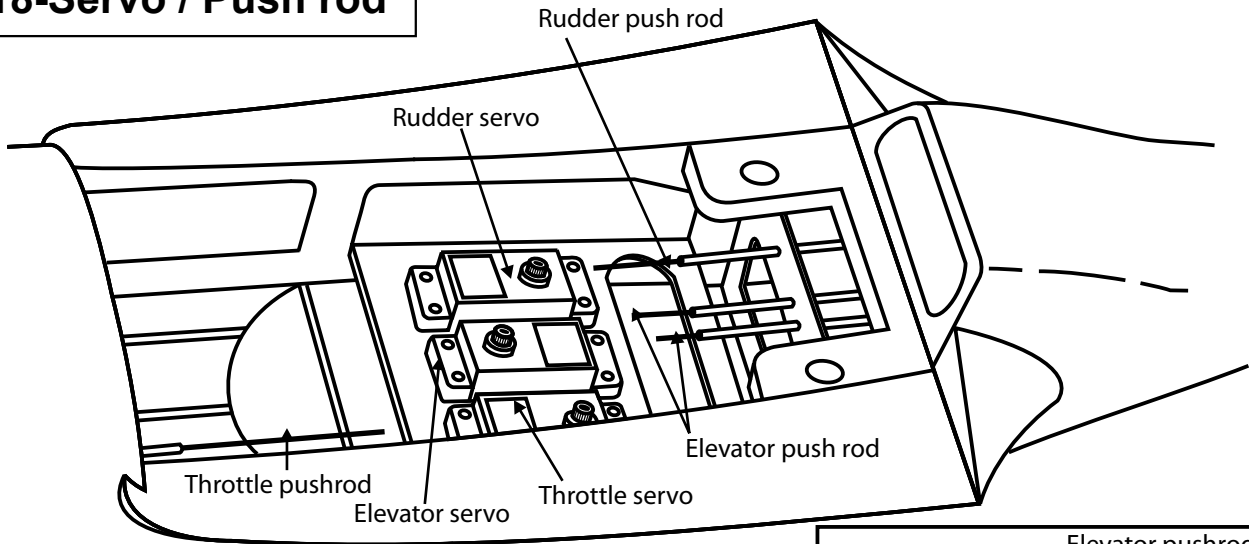

Connector



..... 3

Connector



..... 1

19-Canopy

Do not use too much CA glue or it will make the canopy and pilot white

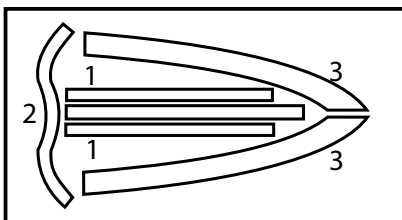
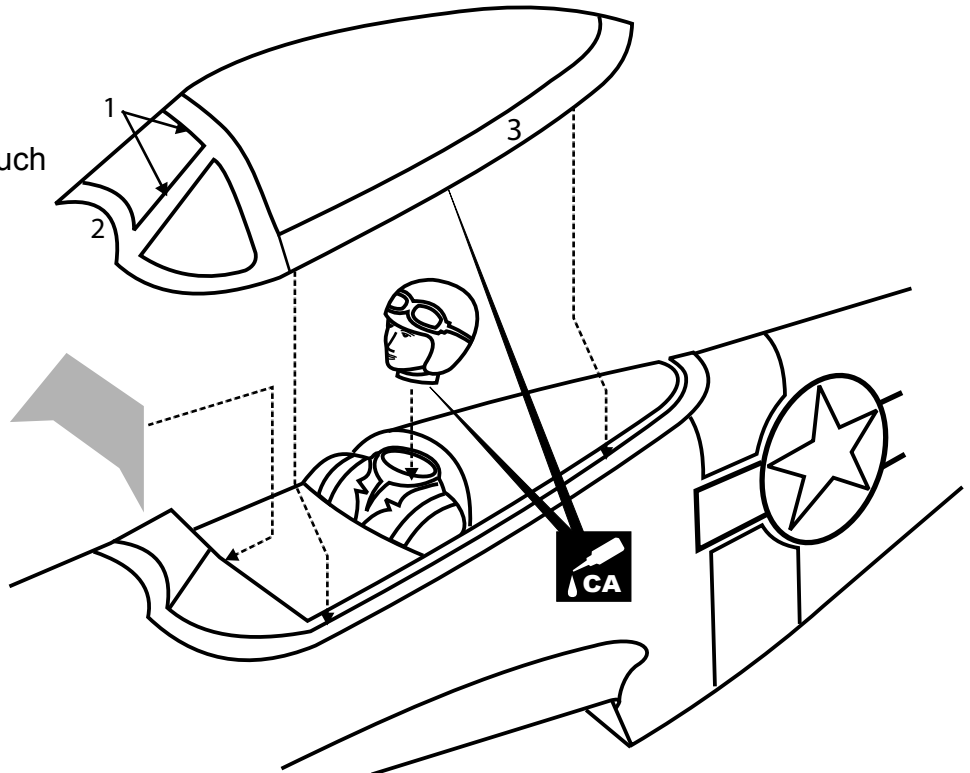

Drill holes using the stated size of drill (in this case 1.5 mm Ø)



Take particular care here



Hatched-in areas: remove covering film carefully



Check during assembly that these parts move freely, without binding



Use epoxy glue



Apply cyano glue



Assemble left and right sides the same way.



Not included. These parts must be purchased separately

20- Cowling

The box art can be used for the placement of the decal

Decal

Relieve the cowl to clear the engine head

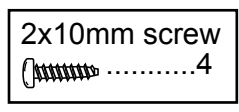
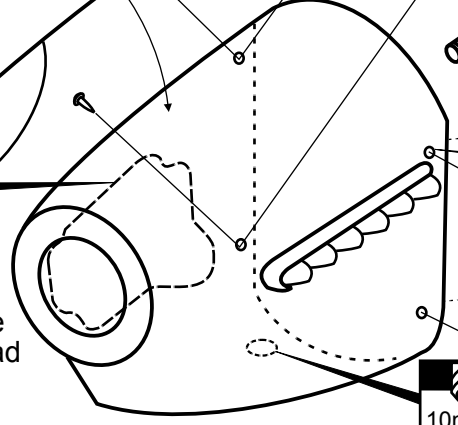
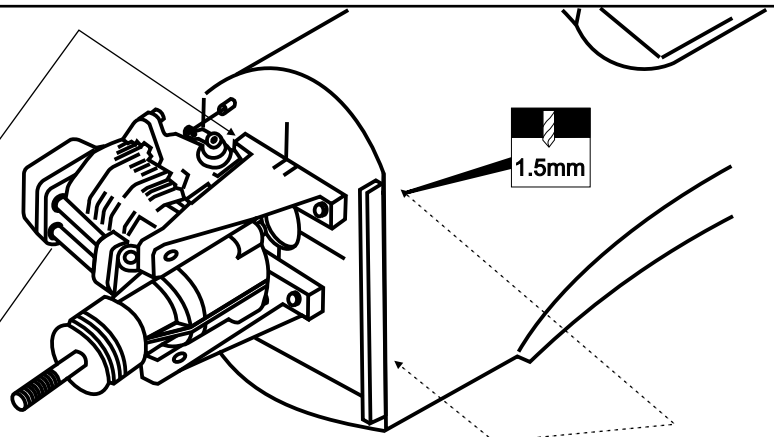

21- Balance

DO NOT try to fly an out-of-balance model !

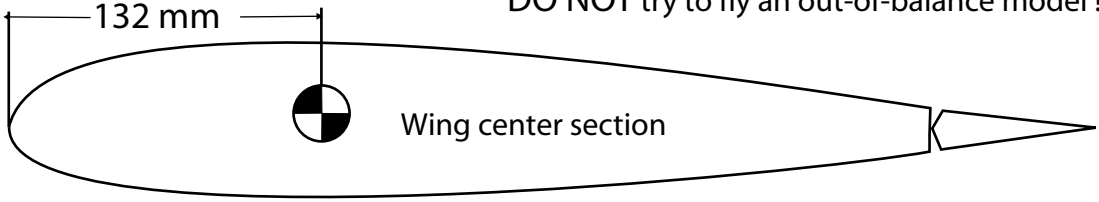

22- Control Surface

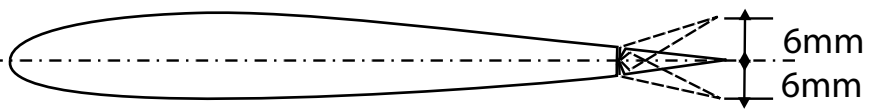

AILERON STROKE

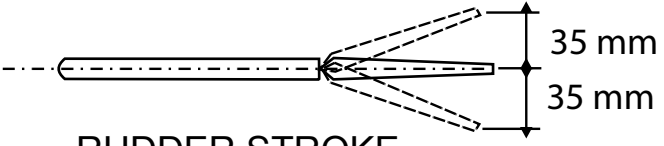

RUDDER STROKE

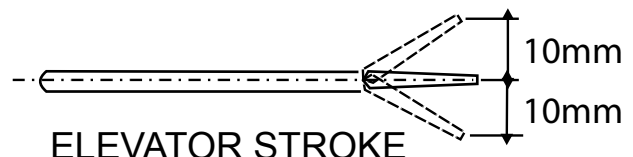

ELEVATOR STROKE